

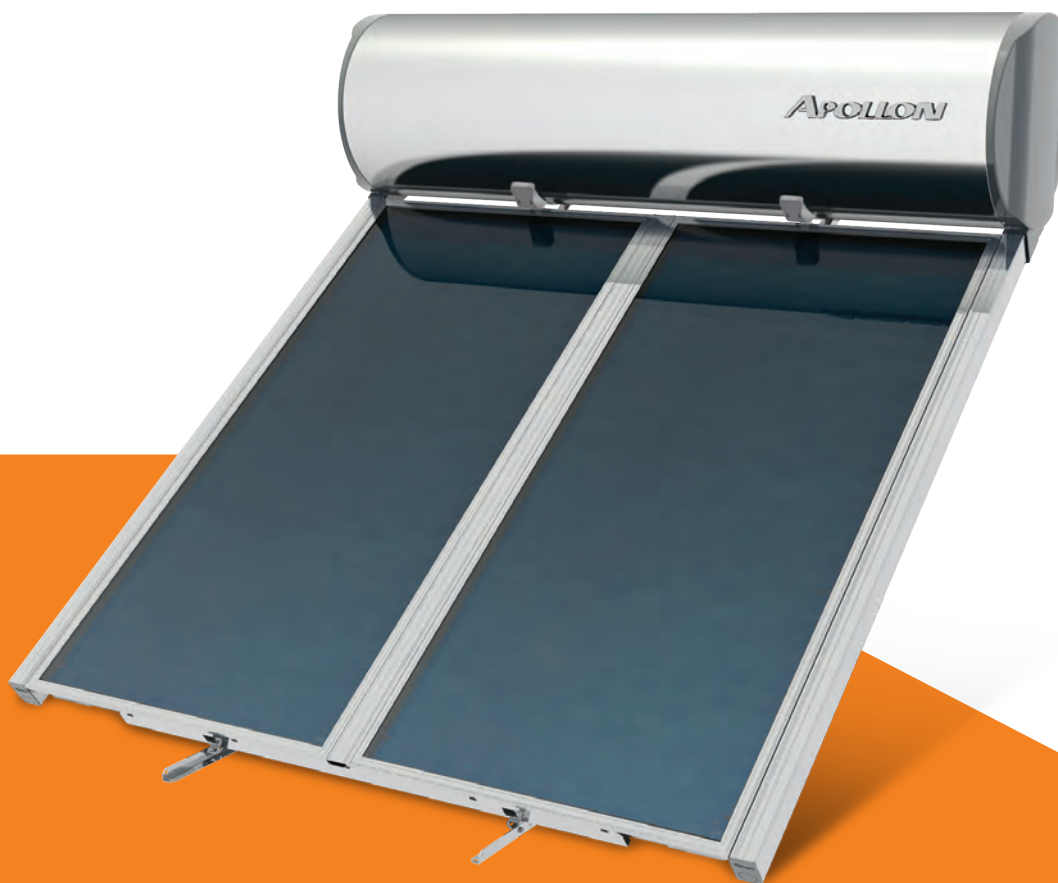

## *Technical Manual*



*Solar water heaters*  
**APOLLON®**

*Installation, maintenance & use instructions*



## CONTENTS

▶ GENERAL INFORMATION.....	4
▶ DOMESTIC HOT WATER CONSUMPTION.....	4
▶ SOLAR WATER HEATER OPERATION - WATER HEATING .....	4
▶ SOLAR WATER HEATERS APOLLON .....	5
▶ PACKAGING .....	5
▶ LABELING .....	7
▶ WATER STORAGE TANK SPECIFICATIONS.....	8
▶ COLLECTOR APOLLON AL SPECIFICATIONS .....	9
▶ APOLLON 160lt/2m <sup>2</sup> LAYOUT .....	11
▶ APOLLON 200lt/2.6m <sup>2</sup> LAYOUT.....	12
▶ APOLLON 320lt/4m <sup>2</sup> LAYOUT .....	13
▶ GENERAL INSTALLATION RULES .....	14
▶ INSTALLATION POSITION .....	15
▶ GENERAL PREVENTION MEASURES.....	16
▶ SUPPORT BASE PARTS.....	17
▶ SUPPORT BASE ASSEMBLY FOR FLAT SURFACES .....	18
▶ SUPPORT BASE ASSEMBLY FOR INCLINED SURFACES .....	21
▶ HYDRAULIC CONNECTION.....	24
▶ CLOSED LOOP FILLING .....	24
▶ ELECTRICAL CONNECTION .....	25
▶ SYSTEM INSTALLATION ON A TILED ROOF WITH THE WATER STORAGE	
▶ TANK UNDER THE ROOF (Natural circulation operation).....	26
▶ CONNECTING THE COIL HEAT EXCHANGER.....	26
▶ POSSIBLE PROBLEMS - SOLUTIONS.....	27
▶ SERVICE - MAINTENANCE .....	28
▶ POST INSTALLATION INSTRUCTIONS.....	29
▶ CHECK LIST .....	30

## GENERAL INFORMATION

**In the present manual you will find all necessary instructions with regard to the installation, operation and maintenance of the product.**

The company is active in the Solar Energy Field with high-tech equipment, ultra-modern facilities and certified products of high quality. Our experience and know-how support our co operations, before and after sales, both in Europe and internationally.

Nowadays, the necessity for production and saving of energy without at the same time polluting the environment has become common knowledge. The planet's conventional energy resources are diminishing to a threatening level as our society's energy requirements are increasing, generating pollutants that affect the climate's balance. Renewable energy sources promise a solution to the energy problem as well as to pollution. Gradually, the international legislation is changing and encouraging - or even imposing - the use of alternative energy products, with the aim to satisfy energy requirements without endangering the environment.

## DOMESTIC HOT WATER CONSUMPTION

Statistically, it is estimated that the mean family consumption is 35 to 50 liters daily per person. If we add the consumption of a washing machine and a dishwasher, when these are connected to the solar water storage tank, then each requires 20 liters per day (per wash). Thus, a family of four, for example, with a mean hot water consumption of 40 liters per person, needs an 160 liters solar water heater. If household appliances connected to the solar water heater are added, then the demand increases by at least 40 liters daily. In order to take full advantage of the solar water heater, maximum use of hot water should be made during daytime, so that the system can continuously produce hot water during the daylight hours, maintaining thus its maximum efficiency.

## SOLAR WATER HEATER OPERATION - WATER HEATING

The collecting surface absorbs solar energy and heats the liquid (water or antifreeze mixture) that circulates in the water element. This liquid when heated becomes lighter and is directed to the water storage tank where it heats the water. The flow of the collector's liquid is accomplished naturally and not forced (thermosiphonic flow).

The factors that affect the temperature of the water supplied by a solar system are many and their values vary according to the season, the time of day and the location. Keeping in mind that the solar system is a system that is exposed to the weather conditions, basic parameters affecting its performance are the mains water temperature, the available solar energy and the ambient temperature. The mains water does not have a constant temperature throughout the year, being much colder in winter compared to summer. Considering 45°C as a v temperature for the domestic hot water (in order to fulfil the needs of a home) and based on statistic values, in winter the temperature of the mains water has to be increased by approximately 35°C, whereas during the summer the increase is 20°C.

Similarly, the available solar energy does not remain the same throughout the year, being much less in the winter months than in the summer months. During periods of reduced sunlight and low ambient temperatures, the solar water storage tank assures the preheating of the water and is assisted by an electrical heating element or the central heating water storage tank (triple action solar water storage tanks). As far as night-time temperature losses are concerned, these are limited as much as possible by the solar system's powerful thermal insulation. They are nevertheless affected by ambient temperatures, which vary depending on the location and the weather.

## SOLAR WATER HEATERS APOLLON

### RELIABILITY - HARMONY - AESTHETICS

- High aesthetics and **design without obvious piping**.
- All the connections between water storage tank and collector are found by the side of the system.  
**The pipes, the cables and the connection elements are covered by special decorative ABS UV PROOF.**



**APOLLON Solar Systems constitute an ecological proposal** and an effective energy solution, combining high output, autonomy, aesthetics, facility in the installation and money saving. They are made of excellent materials according to international specifications and have all the certifications and tests that confirm their quality.

They are highly **aesthetic systems**, which can be simply and quickly installed to blend with the traditional or modern architecture of a building and to provide free hot water almost the whole year round. Even in regions with low sunlight they achieve the preheating of the water, which contributes to a drastically reduced consumption of conventional energy.

With the use of solar systems, thermosiphonic or forced circulation, is achieved energy **saving of 70-100%**. At the same time the operation time of the boiler or electric resistance is decreased, depending on the sunlight of each region and the system's size, with simultaneous reduction of emission of carbon dioxide.

## PACKAGING

### PRODUCT RANGE

**APOLLON series thermosiphon systems** are available in the following models:

MODEL	DESCRIPTION
APOLLON 160/2	160lt tank, 2.0m <sup>2</sup> collector
APOLLON 200/2.6	200lt tank, 2.6m <sup>2</sup> collector
APOLLON 320/4	320lt tank, 2x2.0m <sup>2</sup> collectors

1. Boiler
2. Collector(s)
3. Support base, fittings & Accessories
4. Palette

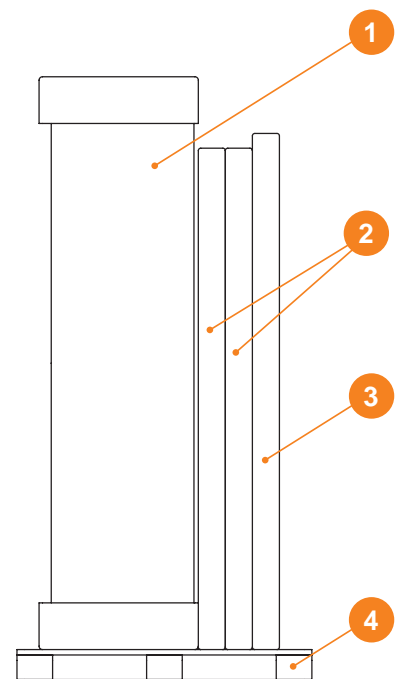

**Each model packaging contains all the necessary equipment:**

1. The water storage tank
2. The collector (s)
3. The support base system & fittings and accessories

The water storage tank is placed between two round styrofoam covers, which are tightened on the storage tank with stretch film.

All the parts of the support base system, with the connection fittings, the antifreeze liquid and the other accessories are packed in a carton box. The fittings and the accessories of each appliance appears in the following table:

<b>SOLAR WATER HEATERS FITTINGS &amp; ACCESSORIES</b>					
Apollon 160/2 & Apollon 200/2.6			Apollon 320/4		
	Quantity	Description		Quantity	Description
	1 PC	T-PIECE WITH THE FILLING VALVE		2 PCS	CONNECTOR Ø22 COPPER X Ø22 COPPER
	1 PC	ELBOW ¾" FEMALE DN 16 INOX		1 PC	T-PIECE WITH THE FILLING VALVE
	2 PCS	ELBOW ½" FEMALE X ½" MALE		2 PCS	ELBOW ¾" FEMALE DN 16 INOX
	2 PCS	ELBOW Ø22 COPPER X DN 16 INOX		2 PCS	ELBOW ½" FEMALE X ½" MALE
	2 PCS	END CAP Ø22 COPPER		2 PCS	ELBOW Ø22 COPPER X DN 16 INOX
	1 PC	ONE WAY SAFETY VALVE 8 bar **		2 PCS	END CAP Ø22 COPPER
	1 PC	SAFETY VALVE (1,5 bar for 250lt and above or 2,5 bar up to 200lt)		1 PC	ONE WAY SAFETY VALVE 8 bar **
	2 PCS	INOX TUBE DN 16		1 PC	SAFETY VALVE (1,5 bar for 250lt and above or 2,5 bar up to 200lt)
	1 PC	INSULATION Ø22 X 9		2 PCS	INOX TUBE DN 16
	2 PCS	BASE COVER		1 PC	INSULATION Ø22 X 9
	1 SET OF 2 PCS	PIPERWORK COVER (ALUMINIUM PROFILE)		2 PCS	BASE COVER
	1 SET OF 2 PCS	PLASTIC COVER CAPS FOR PIPERWORK COVERS		1 SET OF 2 PCS	PIPERWORK COVER (ALUMINIUM PROFILE)
	1 SET OF 2 PCS	PLASTIC PIPE COVERS EXTENSION		1 SET OF 2 PCS	PLASTIC COVER CAPS FOR PIPERWORK COVERS
	*	ANTIFREEZE LIQUID 1lt		1 SET OF 2 PCS	PLASTIC PIPE COVERS EXTENSION
				*	ANTIFREEZE LIQUID 1lt
				1 PC	MIDDLE COVER (ALUMINIUM PROFILE)
				1 SET OF 2 PCS	MIDDLE COVER SUPPORTS (ALUMINIUM PROFILE)

\* The volume of liquid depends on the configuration boiler/collector  
 \*\* ½" BSP up to 200lt or ¾" for 250lt and above

## LABELING

APOLLON solar water heaters are identified by two stickers, one of them on the tank and the other on the collector. On these stickers all the details of the system are written. The information provided on the stickers are important for the future identification of the system.

Solar Water Heater  
APOLLON XXX/XX

- Absorber area: XXX m<sup>2</sup>
- Aperture area: XXX m<sup>2</sup>
- Nominal capacity: XXX lt
- Design pressure: XXX KPa
- Heat transfer medium:  
Propylene glycol / water mixture
- Permissible operating pressure of the collector heat transfer medium: XXX KPa
- Electrical Power: XXXX W **CE**
- Storage Tank S/N: ?????
- Date of manufacture: ?????

MADE IN EU

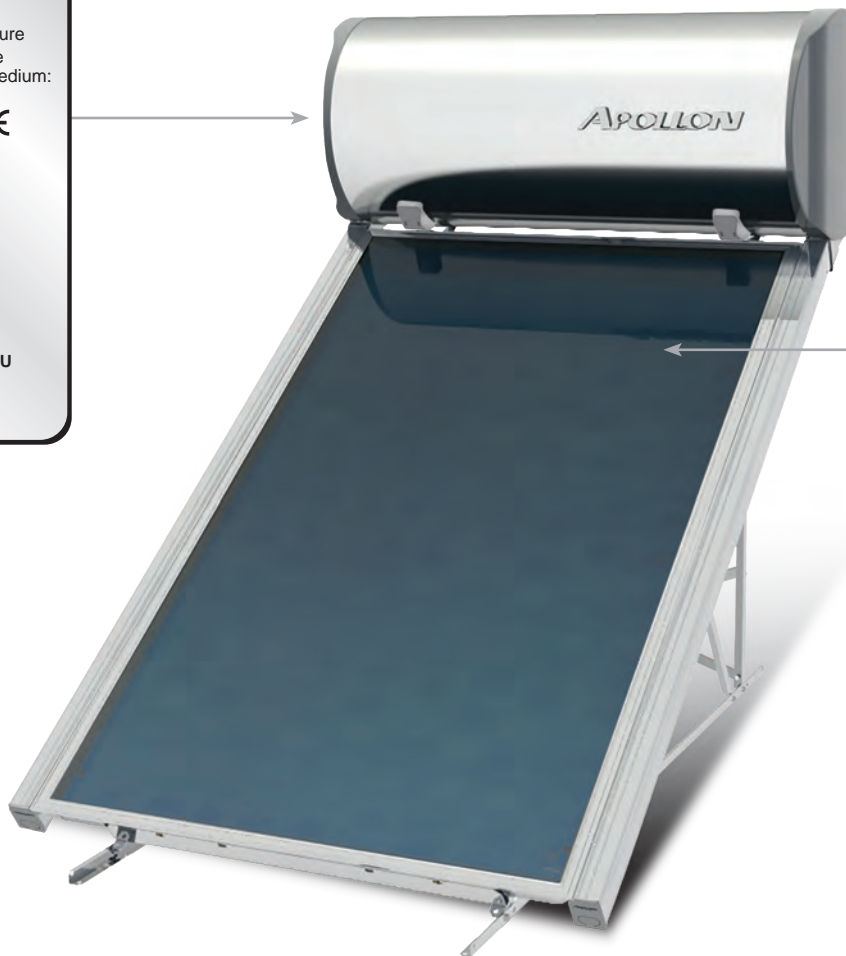

APOLLON AL XXXX

Type: Flatplate collector  
 Dimensions: (L x W x H) (mm): XXXX x XXXX x XX  
 Overall area (m<sup>2</sup>): XXX  
 Absorber area (m<sup>2</sup>): XXX  
 Total weight of collector (kg): XXX  
 Volume of heat transfer fluid (lt): XXX  
 Absorber coating: High selective vacuum coating  
 Standstill temperature: XXX°C  
 Max. operating pressure: 0.8 MPa (8 bar)  
 Transparent cover: Tempered, low-iron solar glass  
 Heat transfer medium: Propylene glycol solution/water mixture

**CE**

Licence No: XXX  
 S/N: XXX  
 Date: XX/XXX

MADE IN EU

## WATER STORAGE TANK SPECIFICATIONS

### STEEL - ENAMEL

1. **Cylinder:** 3mm thickness cold rolled steel with a double internal layer of enamel, baked at 860°C according to DIN 4753. The enameling is done in our own high tech industrial facilities. The water storage tanks are checked individually upon exit from the enameling unit, assuring the top quality of the enamel.
2. **Surrounding heat exchanger (Jacket):** cold rolled steel, 1.8mm thickness for the operation of the closed loop, which is compulsory at low temperatures and also in areas with water with high mineral content. It is specially designed so as to absorb the heat transfer medium pressure.
3. **Thermal insulation:** ecological, high-density, expanded polyurethane ensures minimum heat loss, maintaining the hot water temperature.
4. **External housing:** naval aluminium alloy.
5. **Cathode protection** by magnesium anodes for effective protection against corrosion and mineral deposits caused by electrolytic reactions.
6. **Large round flange rubber protected:** innovative, smart design for the quick cleaning of minerals, fast replacement of anode and immediate access to the electrical components.
7. **Complete sealing** of EPDM, non toxic material, which does not permit water to contact the flange, thus protecting it against electrolysis and corrosion, specially made to withstand the generally accepted specifications with regard to the heat resistance.
8. **Heating element rated** according to the country of destination local regulations. (Optional, for the use of electricity as an auxiliary power source). All electrical components carry a CE marking according to EN 60335-1 and EN60335-2-21 standards.
9. **Automatically regulated thermostat** with bipolar protection and auxiliary fuse. All electrical components carry a CE marking according to EN 60335-1 and EN60335-2-21 standards.
10. **Protective cover:** designed to ensure the proper ventilation of the electrical section and its protection from the environmental conditions.  
**Gland:** for sealing the passage of the heating element's connection cable.
11. **Cold water inlet:** brass ½" BSP male threaded pipe end for water stratification and 8 bar safety valve for releasing pressure (¾" for 250lt and above).
12. **Hot water outlet:** ½" BSP male threaded pipe end (¾" for 250lt and above).
13. **Jacket inlet:** ¾" BSP male threaded pipe end.
14. **Jacket outlet:** Closed loop circuit filling point: ¾" BSP male threaded pipe end.
15. **Safety valve connection location 1,5 bar (for 250lt and above) or 2,5 bar (up to 200lt) :** ½" BSP male threaded pipe end
16. **External decorative covers** made of ABS UV PROOF cover all joints, eliminating visible piping.
17. **Heat exchanger** (optional) enameled steel coil with ¾" BSP male threaded ends for use of the heating produced by central heating systems during the winter the winter (optional)

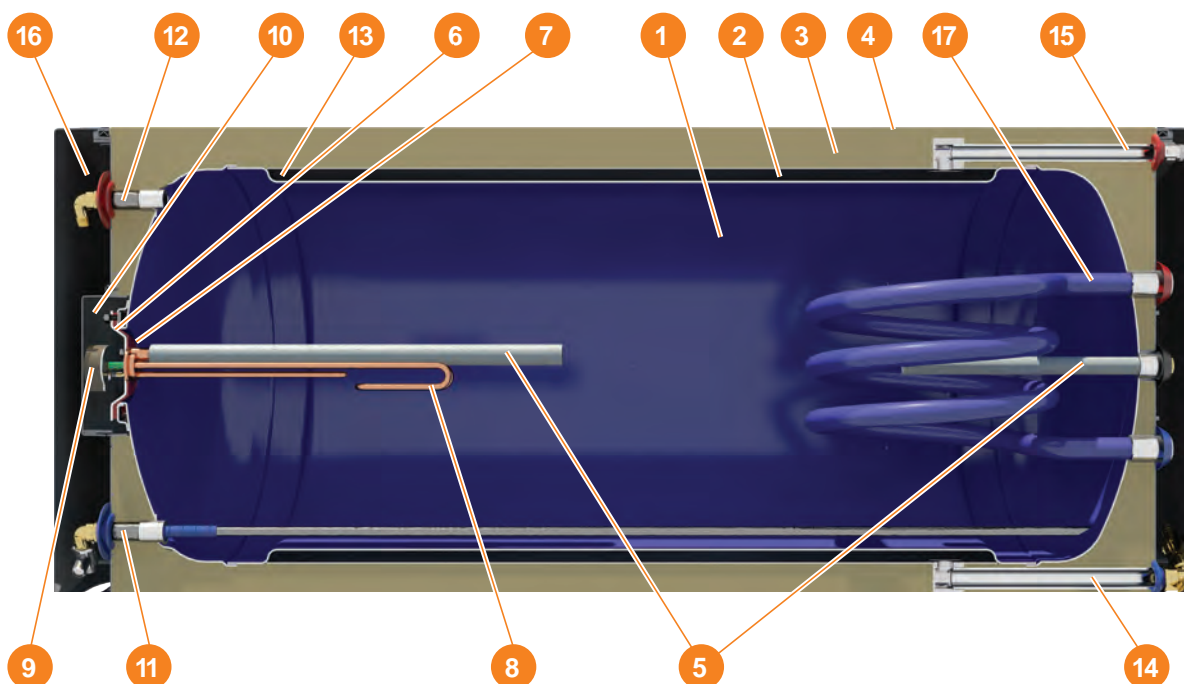



### COLLECTOR APOLLON AL SPECIFICATIONS

1. **External one piece aluminium** trough of high aesthetics, shaped by deep drawing method in 400 tn capacity press, made of naval aluminium alloy, rich in magnesium. Robust construction for perfect tightness.
2. **High density, eco-friendly thermal insulation** achieved with a 60mm thick layer of prepressed rockwool with a covering of black glass fabric for the minimization of thermal losses.

**Rockwool insulation thermal conductivity:**  $\lambda=0.035$  W/m grd (DIN 56612, measured at 0°C)

3. **Water frame of copper pipes** of suitable gauge and thickness (headers: Ø22, manifolds: Ø8) **Headers are punched with upper expansion**, for perfect manifolds fitting, thus avoiding pressure drop in the collectors.  
(tube pitch) = 93mm (EN 1652).
4. **Sun-Selective complete area absorber** made of selective aluminium sheet with a special titan coating formed in vacuum, of high absorbency and low radiation, covers the complete window area as well as the headers, thus increasing the collector's absorbency, Laser Welded to the water frame.
5. **Special plastic parts** for supporting and sealing the water frame to the trough, specially designed for the **collector's ventilation**, with sensor supporting option.

Special silicone rubber seals **allow fluctuation of the absorber's length** (contraction - expansion) in a -40°C to +200°C temperature range.

6. **Tempered solar glass low iron**, with a stable coefficient of expansion and high light transmittance, can withstand adverse weather conditions (e.g. hail storm, extreme temperature changes, etc.).
7. **Solar glass rubber seal:** UV proofed
8. **Aluminium profile electrostatically painted (Al Mg Si 05):** for solar glass seating and supporting.

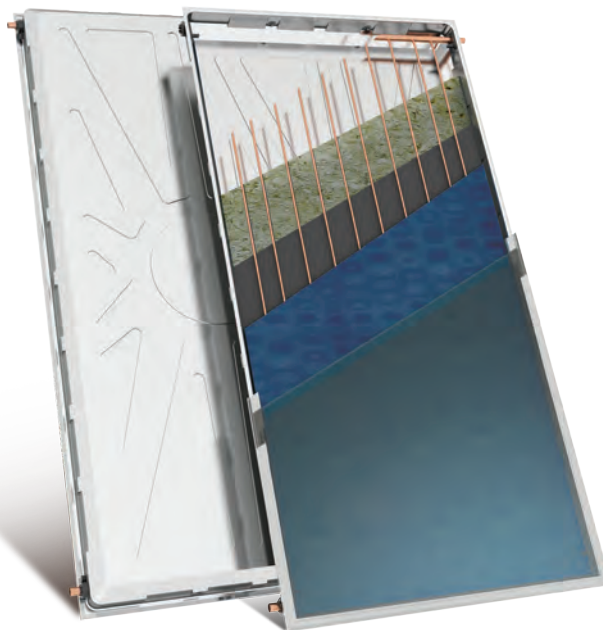

**The Solar Keymark**  
CEN Keymark Scheme

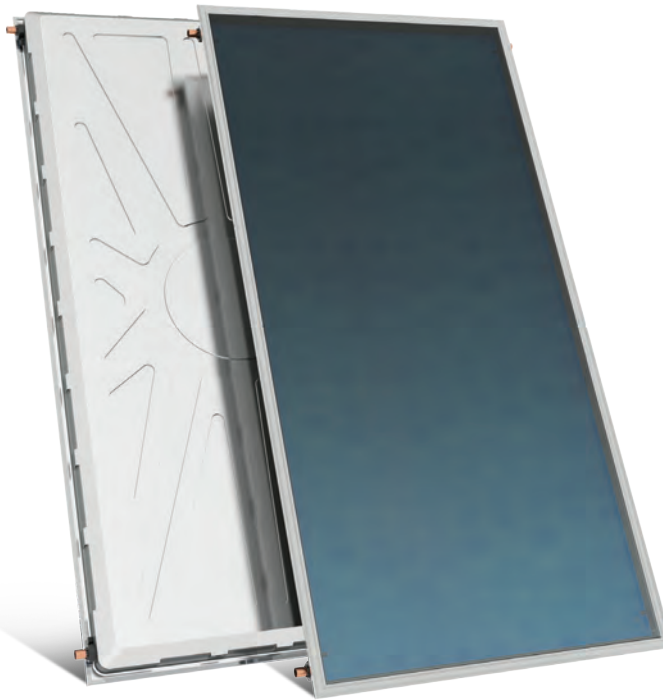

YEARLY ENERGY OUTPUT (kWh/m <sup>2</sup> )	
APOLLON AL 2000, $\vartheta_m = 50^\circ\text{C}$	
ATHENS - GREECE	1.493
DAVOS - SWITZERLAND	1.066
STOCKHOLM - SWEDEN	744
WÜRZBURG - GERMANY	801

**Normal absorber design with louvers.**

Air turbulence increases heat loss

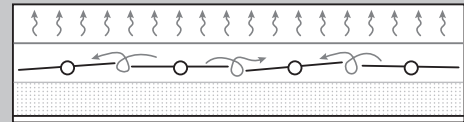

**Complete area technology**

The uniform area prevents heat loss

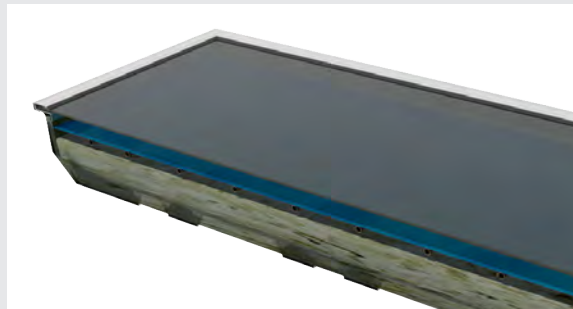
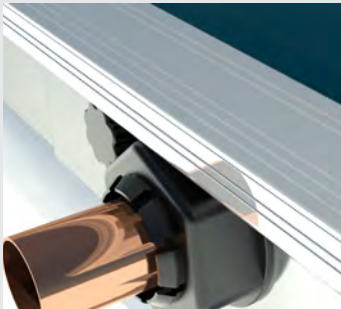
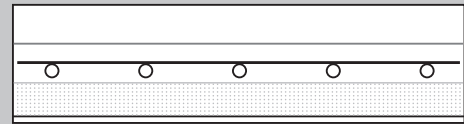

## SUPPORT BASE

Supporting base system, made of electrostatically painted galvanised steel with stainless steel screws and nuts, for installation on **flat** or **inclined** surfaces

FLAT SURFACE



INCLINED SURFACE

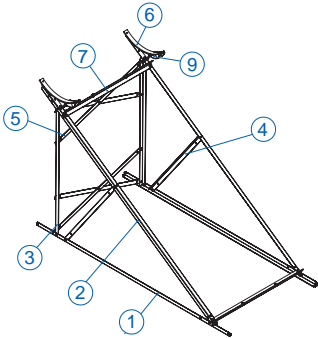

# APOLLON 160lt / 2.0m<sup>2</sup> LAYOUT

FLAT SURFACE		Nº PART NAME	DIMENSION	QTY.
		1 Beam L (Laminate section 60 x 2.5)	2060 x 60	2
		2 Beam L (Laminate section 60 x 2.5)	2250 x 60	2
		3 Beam L (Laminate section 60 x 2.5)	1190 x 60	2
		4 Beam L (Laminate section 60 x 2.5)	925 x 60	2
		5 Beam (Laminate section 33 x 2)	980	4
		6 Boiler Support	Ø580	2
		7 Collector Support	940	2
		8 Protective Cover	420	2
		9 Plastic Cover for Supporting Strips (Slab)		2
		11 Hexagon Head Bolt M8	M8 x 16	32
		12 Hex Nut M8		28
		13 Washer	Ø8	4
		14 Screw 8 x 60		4
		15 Upat D10		4
		16 Hexagon Head Screw with Washer		4

INCLINED SURFACE		Nº PART NAME	DIMENSION	QTY.
		1 Beam L (Laminate section 60 x 2.5)	2060 x 60	2
		2 Beam L (Laminate section 60 x 2.5)	2250 x 60	2
		3 Beam L (Laminate section 60 x 2.5)	925 x 60	2
		4 Beam L (Laminate section 33 x 2)	980	2
		5 Beam (Laminate section 33 x 2)	980	2
		6 Boiler Support	Ø580	2
		7 Collector Support	940	2
		8 Protective Cover	420	2
		9 Plastic Cover for Supporting Strips (Slab)		2
		11 Hexagon Head Bolt M8	M8 x 16	24
		12 Hex Nut M8		20
		13 Washer	Ø8	4
		14 Screw 8 x 60		4

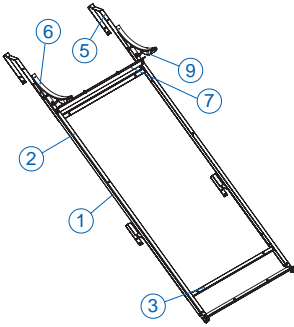
FLAT SURFACE		INCLINED SURFACE	
			

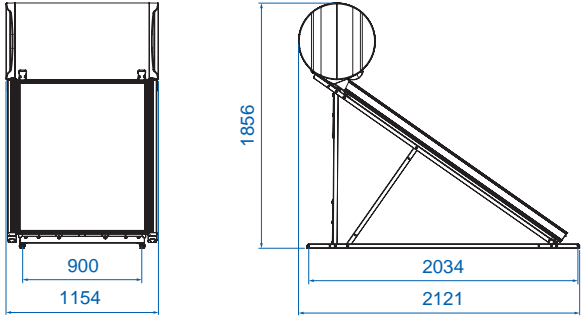
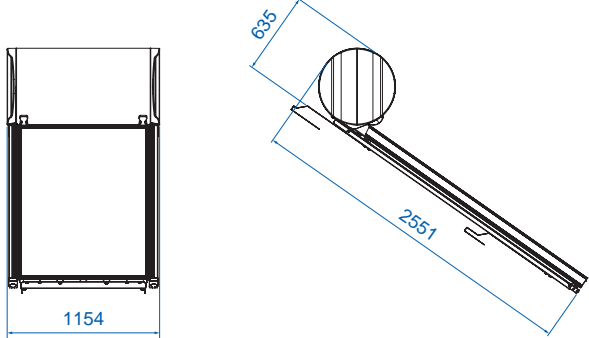
WATER STORAGE TANK	160lt
DIMENSIONS (mm)	580x1150
WEIGHT EMPTY (kg) (without packaging)	66
JACKET CAPACITY (lt)	9
JACKET SURFACE (m <sup>2</sup> )	0.91
MAX TEST PRESSURE (bar)	12
MAX OPERATING PRESSURE (bar)	8

TOTAL SYSTEM / APOLLON	160lt/2m <sup>2</sup>
NUMBER OF COLLECTORS	1
SYSTEM WEIGHT EMPTY / FULL (kg)	137 / 302
MAX WATER TANK OPERATING PRESSURE (bar)	8
CLOSED CIRCUIT MAX OPERATING PRESSURE (bar)	2.5
MAX OPERATING TEMPERATURE	95°C

COLLECTOR / APOLLON	AL 2000
TOTAL AREA (m <sup>2</sup> )	2.03
NUMBER OF MANIFOLDS	10
HEAT TRANSFER MEDIUM	PROPYLENE GLYCOL SOLUTION
CAPACITY (lt)	1.75
ABSORBER SURFACE (m <sup>2</sup> )	1.81
TOTAL DIMENSIONS (mm)	2010x1010x110
COLLECTOR TOTAL WEIGHT (without liquid) (kg)	38
ABSORBER	SELECTIVE ALUMINIUM
ABSORBENCY / RADIATION COEFFICIENT	95% ±2% / 5% ±2%

Note: All dimensions measured in mm

# APOLLON 200lt / 2.6m<sup>2</sup> LAYOUT

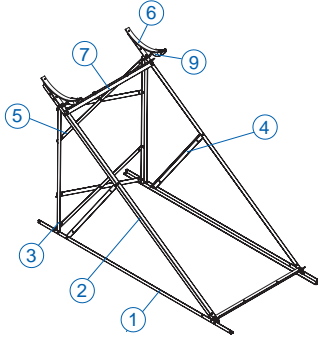
FLAT SURFACE		Nº PART NAME	DIMENSION	QTY.
		1 Beam L (Laminate section 60 x 2.5)	2060 x 60	2
		2 Beam L (Laminate section 60 x 2.5)	2250 x 60	2
		3 Beam L (Laminate section 60 x 2.5)	1190 x 60	2
		4 Beam L (Laminate section 60 x 2.5)	925 x 60	2
		5 Beam (Laminate section 33 x 2)	980	4
		6 Boiler Support	Ø580	2
		7 Collector Support	940	2
		8 Protective Cover	420	2
		9 Plastic Cover for Supporting Strips (Slab)		2
		11 Hexagon Head Bolt M8	M8 x 16	32
		12 Hex Nut M8		28
		13 Washer	Ø8	4
		14 Screw 8 x 60		4
		15 Upat D 10		4
		16 Hexagon Head Screw with Washer		4

INCLINED SURFACE		Nº PART NAME	DIMENSION	QTY.
		1 Beam L (Laminate section 60 x 2.5)	2060 x 60	2
		2 Beam L (Laminate section 60 x 2.5)	2250 x 60	2
		3 Beam L (Laminate section 60 x 2.5)	925 x 60	2
		4 Beam L (Laminate section 33 x 2)	980	2
		5 Beam (Laminate section 33 x 2)	980	2
		6 Boiler Support	Ø580	2
		7 Collector Support	940	2
		8 Protective Cover	420	2
		9 Plastic Cover for Supporting Strips (Slab)		2
		11 Hexagon Head Bolt M8	M8 x 16	24
		12 Hex Nut M8		20
		13 Washer	Ø8	4
		14 Screw 8 x 60		4

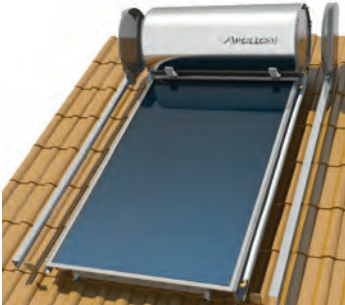
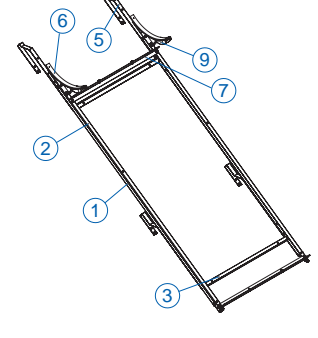
FLAT SURFACE		INCLINED SURFACE	
			

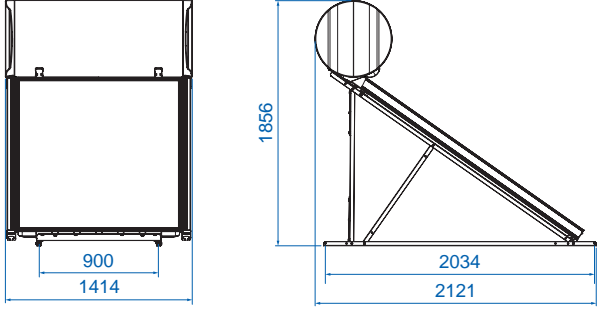
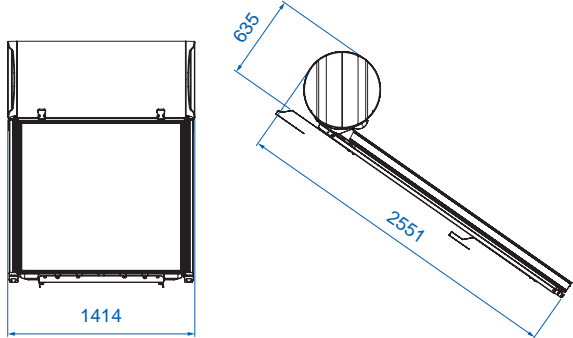
WATER STORAGE TANK		TOTAL SYSTEM / APOLLON	
200lt	200lt	200lt/2.6m <sup>2</sup>	200lt/2.6m <sup>2</sup>
DIMENSIONS (mm)	580x1400	NUMBER OF COLLECTORS	1
WEIGHT EMPTY (kg) (without packaging)	79	SYSTEM WEIGHT EMPTY / FULL (kg)	158 / 368
JACKET CAPACITY (lt)	13	MAX WATER TANK OPERATING PRESSURE (bar)	8
JACKET SURFACE (m <sup>2</sup> )	1.28	CLOSED CIRCUIT MAX OPERATING PRESSURE (bar)	2.5
MAX TEST PRESSURE (bar)	12	MAX OPERATING TEMPERATURE	95 °C
MAX OPERATING PRESSURE (bar)	8		

COLLECTOR / APOLLON		AL 2600
TOTAL AREA (m <sup>2</sup> )		2.53
NUMBER OF MANIFOLDS		13
HEAT TRANSFER MEDIUM		PROPYLENE GLYCOL SOLUTION
CAPACITY (lt)		2.12
ABSORBER SURFACE (m <sup>2</sup> )		2.30
TOTAL DIMENSIONS (mm)		2010x1260x110
COLLECTOR TOTAL WEIGHT (without liquid) (kg)		45.4
ABSORBER		SELECTIVE ALUMINIUM
ABSORBENCY / RADIATION COEFFICIENT		95% ±2% / 5% ±2%

Note: All dimensions measured in mm

# APOLLON 320lt / 4.0m<sup>2</sup> LAYOUT

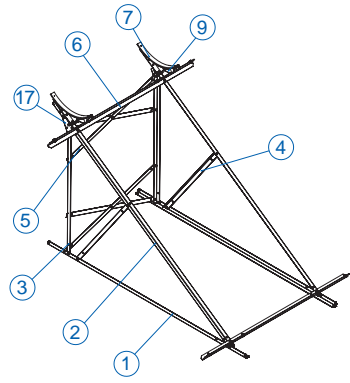
FLAT SURFACE		Nº Part Name	DIMENSION	QTY.
		1 Beam L (Laminate section 60 x 2.5)	2060 x 60	2
		2 Beam L (Laminate section 60 x 2.5)	2250 x 60	2
		3 Beam L (Laminate section 60 x 2.5)	1190 x 60	2
		4 Beam L (Laminate section 60 x 2.5)	925 x 60	2
		5 Beam (Laminate section 33 x 2)	980	4
		6 Collector Support	1500	2
		7 Boiler Support	Ø580	2
		8 Protective Cover	420	2
		9 Plastic Cover for Supporting Strips (Slab)		2
		10 Hexagon Head Screw with Washer		4
		12 Hexagon Head Bolt M8	M8 x 16 St	42
		13 Hex Nut M8		34
		14 Washer	Ø8	8
		15 Screw 8 x 60		4
		16 Upat D10		4
		17 Reinforcing Plate	Left	1
		18 Reinforcing Plate	Right	1

INCLINED SURFACE		Nº Part Name	DIMENSION	QTY.
		1 Beam L (Laminate section 60 x 2.5)	2060 x 60	2
		2 Beam L (Laminate section 60 x 2.5)	2250 x 60	2
		3 Beam L (Laminate section 60 x 2.5)	925 x 60	2
		4 Beam L (Laminate section 33 x 2)	980	2
		5 Beam (Laminate section 33 x 2)	980	2
		6 Collector Support	1500	2
		7 Boiler Support	Ø580	2
		8 Protective Cover	420	2
		9 Plastic Cover for Supporting Strips (Slab)		2
		10 Hexagon Head Bolt M8	M8 x 16	28
		11 Hex Nut M8		20
		12 Washer	Ø8	8
		13 Hexagon Head Screw with Washer		4

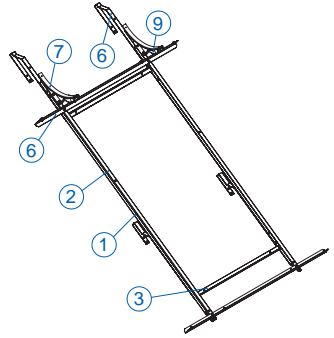
FLAT SURFACE		INCLINED SURFACE	
			

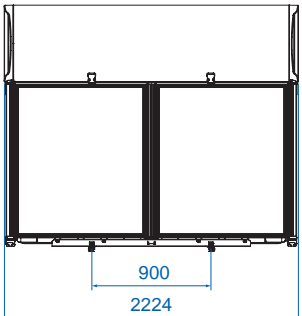
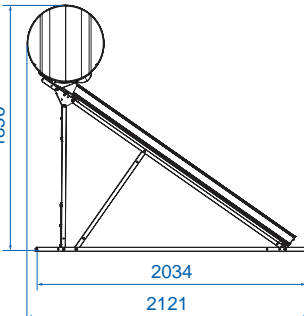
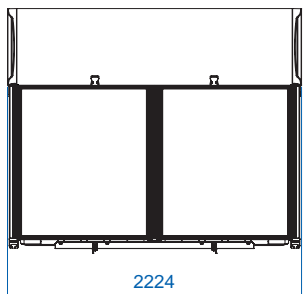
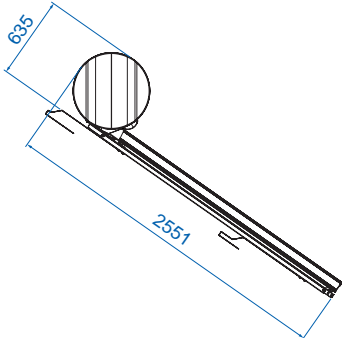
WATER STORAGE TANK	320lt
DIMENSIONS (mm)	580x2210
WEIGHT EMPTY (kg) (without packaging)	118
JACKET CAPACITY (lt)	19
JACKET SURFACE (m <sup>2</sup> )	1.79
MAX TEST PRESSURE (bar)	12
MAX OPERATING PRESSURE (bar)	8

TOTAL SYSTEM / APOLLON	320lt/4m <sup>2</sup>
NUMBER OF COLLECTORS	2
SYSTEM WEIGHT EMPTY / FULL (kg)	231 / 581
MAX WATER TANK OPERATING PRESSURE (bar)	8
CLOSED CIRCUIT MAX OPERATING PRESSURE (bar)	1.5
MAX OPERATING TEMPERATURE	95°C

COLLECTOR / APOLLON	AL 2000
TOTAL AREA (m <sup>2</sup> )	2.03
NUMBER OF MANIFOLDS	10
HEAT TRANSFER MEDIUM	PROPYLENE GLYCOL SOLUTION
CAPACITY (lt)	1.75
ABSORBER SURFACE (m <sup>2</sup> )	1.81
TOTAL DIMENSIONS (mm)	2010x1010x110
COLLECTOR TOTAL WEIGHT (without liquid) (kg)	38
ABSORBER	SELECTIVE ALUMINIUM
ABSORBENCY / RADIATION COEFFICIENT	95% ±2% / 5% ±2%

Note: All dimensions measured in mm

## GENERAL INSTALLATION RULES

**ATTENTION!** Installation must be in compliance with local & national rules concerning water and electrical installations (plumbing, electricity, hygiene, urban and others).

**The solar system's packaging** must be removed at the site of installation in order to protect the device from shocks during its transportation, making sure that the collectors are not supported on their pipe joints. Until installation is completed, the collector's glass must remain covered until the water storage tank is filled with domestic water, so as to avoid the boiling of the filling liquid or the breaking of the glass. The plastic protective caps must be removed from the water storage tank's and the collector's pipe joints.

**Installation location - shading:** Prior to installation, a proper selection of the location must be made by the installer (in agreement with the customer), and the surface must be checked (taking into consideration its static resistance), so that it can bear the weight of the system.

On inclined roofs the system should not be placed between two beams but above a single one.

The position chosen for the solar water heater installation should not be shaded by any obstacles such as trees, buildings and other all year round, so as to ensure at least 4 hours of uninhibited exposure of the collector to the sun during the midday hours.

LATITUDE	DISTANCE BETWEEN THE OBSTACLE AND THE COLLECTOR (L)
0° - 25°	1.0 x H
26° - 35°	1.5 x H
36° - 45°	2.0 x H
46° - 50°	2.5 x H
> 50°	3.0 x H

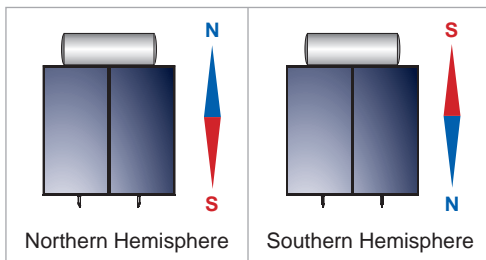
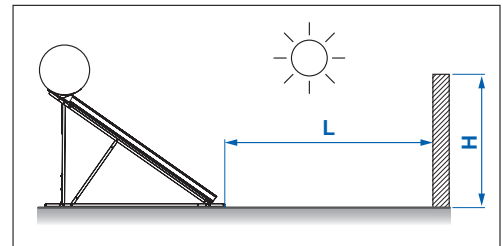

**Orientation - optimum angle:** a basic factor for the system's optimum performance is the selection of its angle and orientation for its particular location and the time during which the maximum gain is required.

The solar system should be positioned so that the collector's surface faces the geographical south, if the installation takes place in the Northern Hemisphere (and the geographical north for the Southern Hemisphere), i.e. it should always face the Equator.

Any deviation means a reduction in the system's performance. If a deviation from the proper orientation cannot be avoided, then the system's performance should be corrected by increasing the collector surface, following a study and evaluation of the specific conditions that apply. As the sun ray's angle of attack varies with time but also depending on the system's location, the collector's angle should be approximately equal to the installation location's latitude. At this angle the maximum energy gain on an annual basis is achieved.

**Installation particularities:** In case there is no compatibility between the surface where the solar water heater will be installed (inclined or flat) and the standard equipment provided with the system, a different kind of equipment should be used. The responsibility for the equipment chosen lies on the installer and in no case on the company. It is up to the installer to propose & install the different equipment required, who must previously agree it with the customer.

**Special weather conditions:** In regions suffering from heavy snowfalls, please make sure that the snow is always timely removed. For this case and cases of regions with storms, high wind velocity, rainfall, cyclones, tornadoes, the system must be placed on the roof as firmly as possible and must be tightened with extra metal stripes. In areas where these conditions occur and hail of more than 20mm in diameter is to be observed, it is recommended that insurance for the solar water heater is issued. In every case, it is recommended to secure your solar water heater on the support base system with more metal belts than those provided.

**Piping:** the routing of the piping and cabling must be agreed upon between the installer and the client, so as to ensure the proper installation of the solar system in compliance with local rules concerning water and electrical installations. Make sure that the tubes connecting the storage tank with the collector and the piping to/from the water heater are insulated in such a way that they can withstand temperatures covering the range of: -30°C to 120°C. Anti-UV protection must be used for the insulation.

**Antifreeze Liquid:** The special heat transfer medium used in the closed circuit protects the system from freezing and from salt accumulation inside the collector tubes. The jacket in which the heat transfer medium's circulation takes place, does not communicate with the water tank. The thermal fluid must be well mixed with water in a percentage that is necessary to protect the system. The responsibility for the appropriate heat transfer medium quantity as well as for the use of other liquid than the one accompanying the solar water heater lies on the installer and in no case on the company.

The use of water or inappropriate liquid may annul the warranty validity.

After the installation is completed, the area where the work was executed should be clean & tidy. The warranty should be filled in and the customer should sign it and immediately mail it to the company. The customer should fill in the check list provided by the company. The company does not hold any responsibility that may be the result of an inappropriate installation or incorrect use of components used for the solar water heater installation.

## INSTALLATION POSITION

The installation is only allowed on roofs and flat surfaces of adequate bearing capacity. Before you proceed with the installation, make sure that the roof and/or the construction is of adequate bearing capacity in terms of statics, always according to the expected maximum loads at the installation point. If the installation is in a place with an extremely big wind and snow load, the system as a whole should be statically checked by a skilled person, e.g. a specialized engineer. In special cases, strengthening or more solid constructions may be required.

*For the proper operation of the system, the minimum recommended inclination angle of the collectors is 20°*

APOLLON AL COLLECTORS		
INSTALLATION MODE	WIND LOAD [km/h] / [kN/m <sup>2</sup> ]	SNOW LOAD [kN/m <sup>2</sup> ]
Inclined surface	151 / 1.5	2.17
Flat surface	151 / 1.5	2.17

*The rates listed in the above table relate to the resistance of the collector that has been tested on an inclined surface with an angle support of 15°-75° and on a flat surface with an angle support of 35°. The system may only be installed in locations with lower wind and snow load values than the ones mentioned above.*

### Space requirements for installation on the roof (TILED ROOF)

For the installation on the roof the following points must be taken care of:

- The minimum distances from the ends of the roof should be:
  - From the sides: distance equal to the width of two tiles
  - From the top of the roof: distance equal to three rows of tiles
- The minimum distance limit of 0.8 m should necessarily be respected, in order for the collectors and the mounting accessories not to be exposed to winds the power of which increases on the perimetrical edges of the roof.

### Space requirements for free standing installation (FLAT ROOF)

The system should be installed at least 1.5 m away from the edges of the roof so as for:

- The systems to be accessible for maintenance reasons.
- The systems and the fixing system not to be exposed to strong winds which are developed at the ends and edges of the roof.
- The snow to be removed.

## GENERAL PREVENTION MEASURES

- Please respect the instructions related to accidents prevention and the safety rules during the installation of the solar thermal systems as well as the piping.
- Please keep the work place clear and free of objects obstructing the execution of works.
- Do not let children, pets and other people to come in contact with the tools or close to the working place. This has to be respected, especially in case of existing buildings renovation.
- Store the antifreeze liquid in a safe place away from children.
- During the execution of maintenance, service or installation modification works, please remove the electrical devices and tools current collector or protect the electrical devices and electrical tools against unintended activation.
- Use only the tools intended to be used for this specific solar system. The use of other components or inappropriate tools can cause accidents.

### *Requirements related to the personnel*

- The installation of our Solar Thermal systems can only be undertaken by authorized specialized companies and trained personnel.
- Works in electrical installations or conductors have to be executed by trained & specialized electro technicians only.

### *Labour uniforms*

- Have protection glasses on, as well as appropriate work uniform, protection shoes, protection helmet and special long hair net.
- Do not wear baggy clothes or jewelry, as they may be trapped in movable parts.
- If, despite the use of protection glasses, antifreeze liquid comes in contact with your eyes, wash off your eyes with plenty of water and with the eyes wide open.
- Please wear protection helmet during the installation works executed at the level of or above the head.

### *Installation of the water storage tank*

- For the transportation, mounting & installation of the tank use forklifts suitable for the dimension and weight of the tank.
- Please protect the enameling surface from beatings during transportation and installation.
- Due to the tank's weight, there is a risk of accidents. Please make sure that the bearing capacity of the ground where the tank is going to be installed is adequate, when the tank is full.

## LIGHTNING PROTECTION

The metal construction conforms to the general requirements of the ELOT 1197 Standard and the special lightning protection requirements of the ELOT 1412 Standard which takes into account the environmental conditions as well as the altitude.



## SUPPORT BASE PARTS

### For 4m<sup>2</sup> collector surface

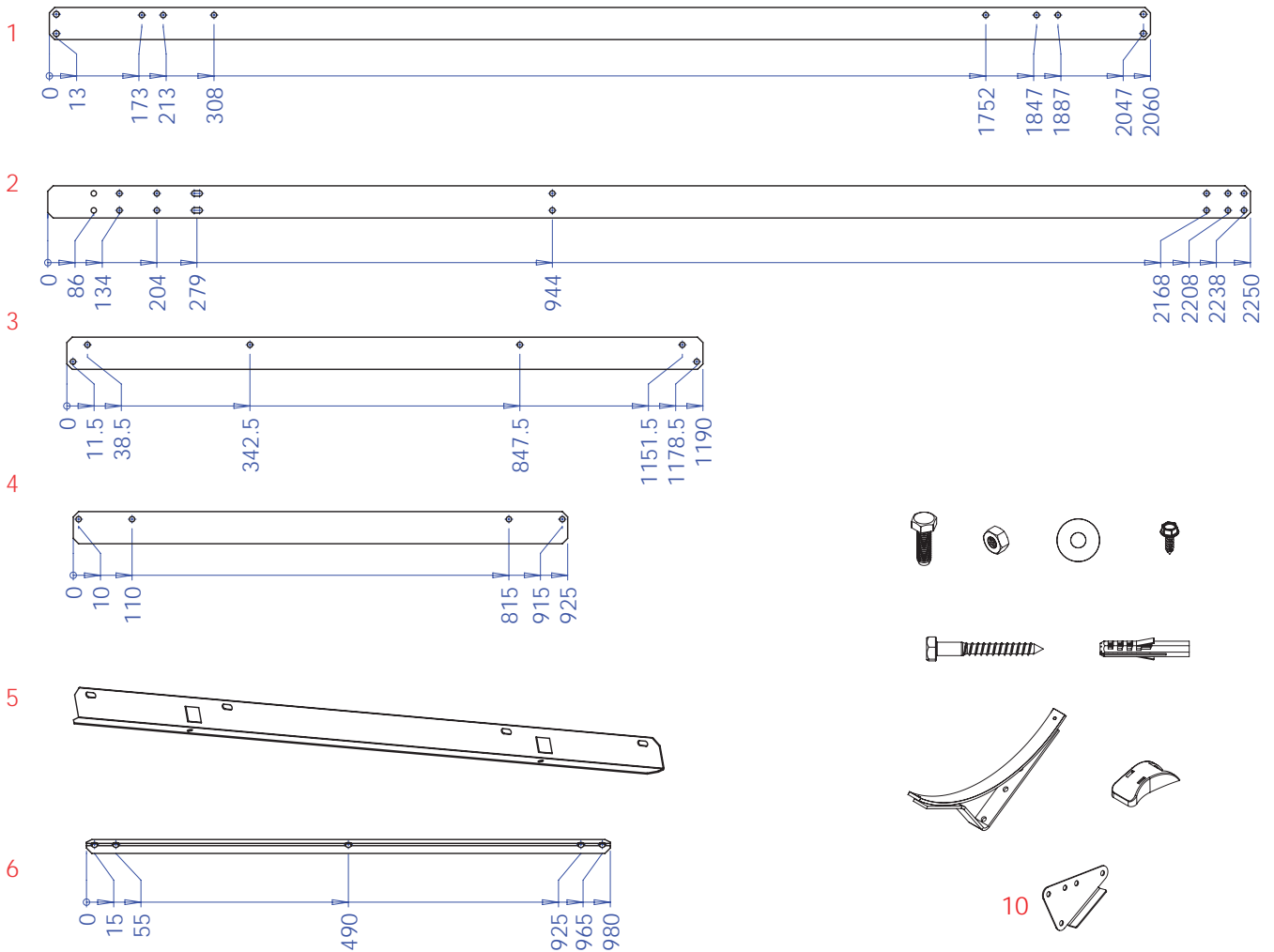

### For 2m<sup>2</sup> & 2.6m<sup>2</sup> collector surface

NOTE: For 2m<sup>2</sup> & 2.6m<sup>2</sup> collector surface systems, part 5 is substituted by the following:



## SUPPORT BASE ASSEMBLY ON A FLAT SURFACE

1. Screw parts 1 to part 2, using the M8 screws and nuts included in the packaging.

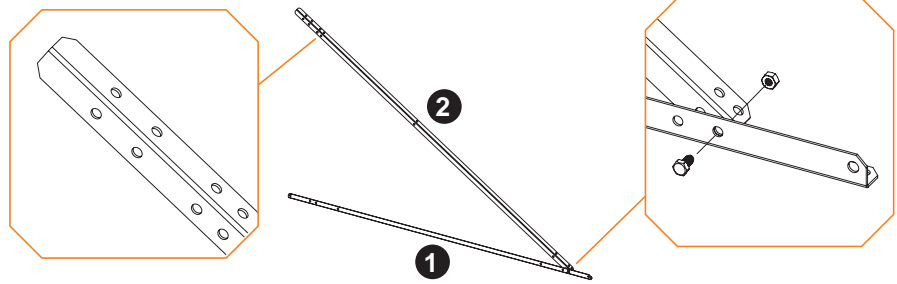

2. Place the vertical part 3 to the above parts

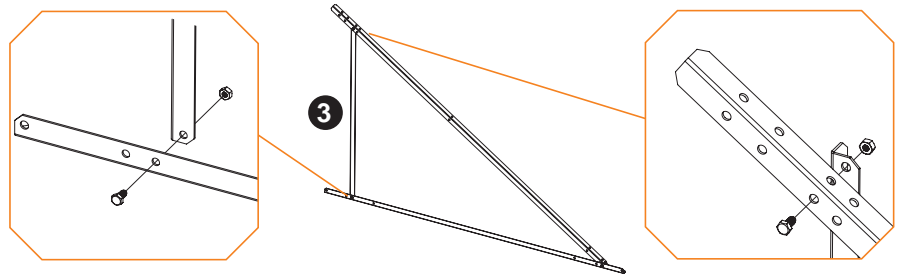

3. Screw part 4 to the rest parts of the frame and tighten all screws. Repeat steps 1, 2 & 3 for the other pairs of parts.

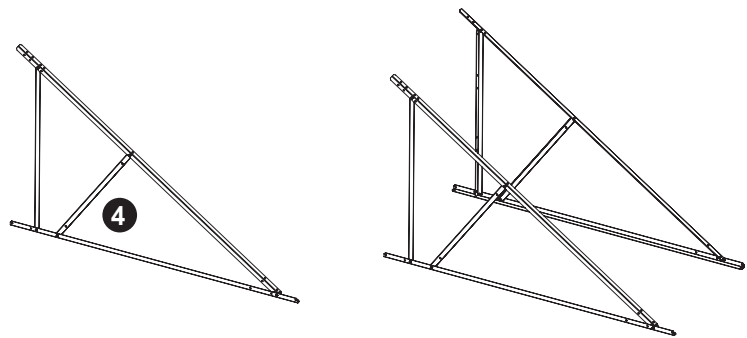

4. Place parts 6 crosswise and tighten the screws.

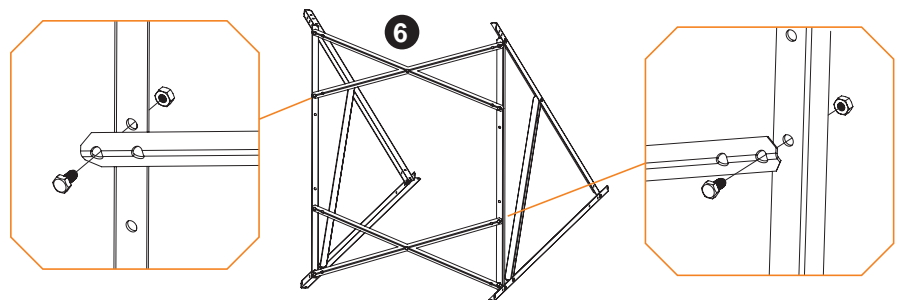

5. In case of two collectors model, place the collector supporting part 5 on bottom part of the frame and tighten all screws.

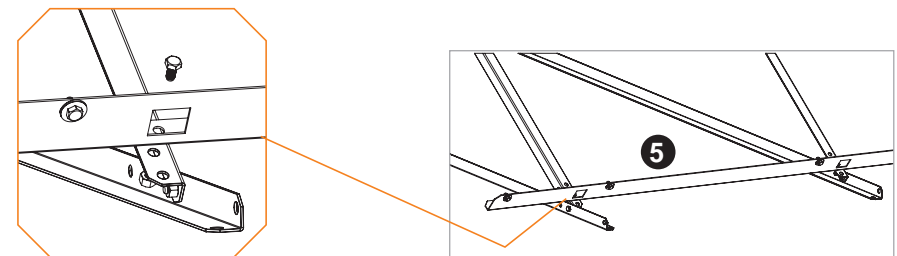

6. Repeat for the upper part

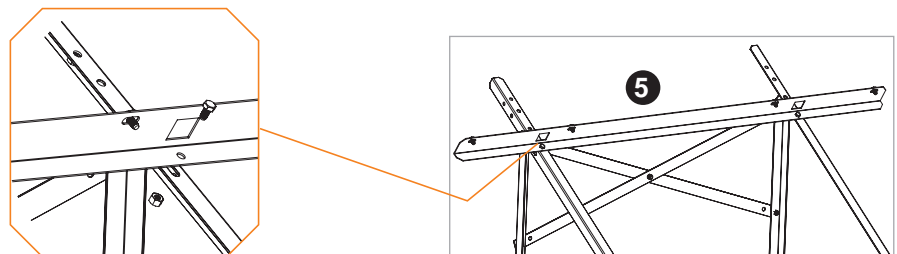

7. In case of two collectors, first place the left one to the bottom part 5 lifting the upper part 5. Place the screws with the support washers of the collector (4 for each collector) without tightening them. Place the Ø22 mechanically tightened unions at the edges of the collector.



8. Join the second collector and tighten the unions\*.

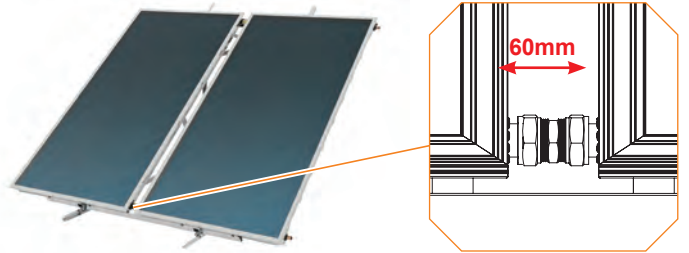

9. Screw on the two supports 7 of the tank. Tighten all screws on the base. Properly orientate the base with the collector. Firmly attach the base using 4 Upat D10 and bolts (M8x60).

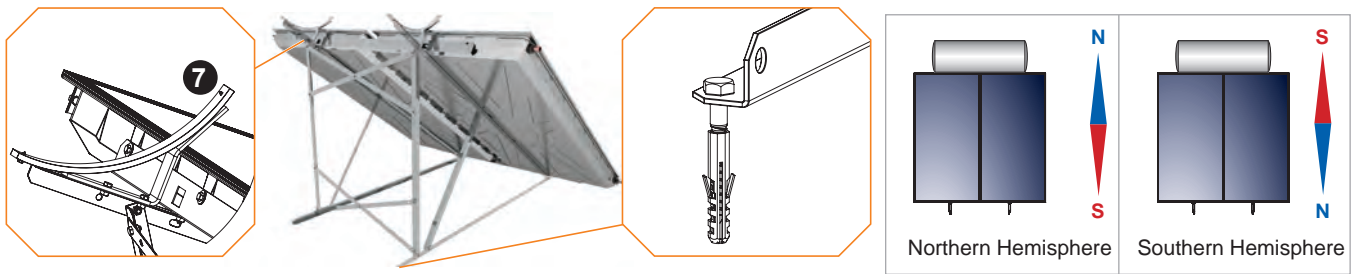

10. Place the decorative covers at the external collector's sides adjusting the channel's aperture at the collector's socket. Screw the channels at the special collector's metal piece using the screws and the corresponding nuts.

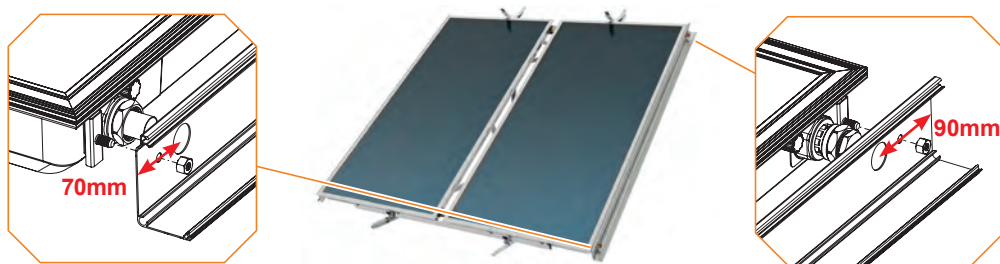

11. In case of 250lt boiler and above screw reinforcing plate (10) to collector beam(2) and vertical beam(3) with bolts M8x16 and nuts. Repeat for another side.

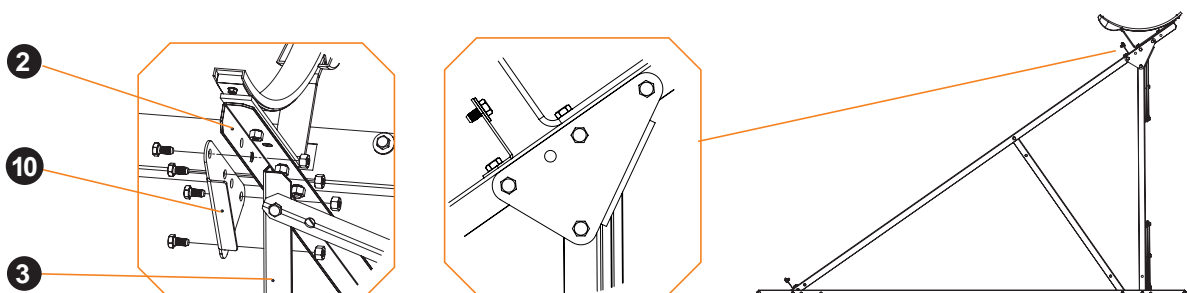



12. Place and tighten the Ø22 mechanically tightened plug on the top right and on the bottom left of the collector/ collectors\*. Place the water storage tank on the base with its electrical components to the left, when viewing the water storage tank from the front.
13. Centre the water storage tank's position on the collector/s. Rotate the water storage tank (if necessary) in order for the cold and hot domestic water sockets to remain vertical to the horizontal surface. Screw the water storage tank onto the base using the screws provided in the packaging. Ensure the appliance is not tilted and is properly levelled. It is necessary to use a level.
14. Place the small flexible tube on the special connection 3/4"xDN16 INOX\* at the water storage tank's side where the heating element is located and to the socket marked "collector intake".
15. Join the other end to the top left socket of the collector using the Ø22 x DN16 INOX corner fitting, having firstly pass the tube through the plastic channel extension.  
**Note:** Through the above extension, pass the cold and hot domestic water sockets during the hydraulic connection.
16. Place the T- piece with the filling valve to the socket on the right side of the water storage tank marked "collector return".
17. Place the big flexible tube with the special connection to the T- piece on the right side of the water storage tank.
18. Place the other end at the bottom right socket of the collector using the Ø22 x DN16 INOX corner fitting\*, having firstly passed the tube through the insulation tube. Tighten all unions in the system as well as all the screws on the base. Do the hydraulic connection, fill the closed loop and do the electrical connection as described in the relevant sections. Check for leaks.
19. Fit all pipe covers and faWsten with the plugs on the bottom part.
20. Place the middle cover at the upper socket. After having placed the collectors at a parallel to each other position, fasten them to the bottom side .
21. Fit the water storage tank supporting base covers.
22. Fit the plastic channel extension at the pipework cover. Check that the water storage tank is completely centred with the plastic channel extensions.
23. Align the water storage tank external flap with the sockets and press to fasten, making sure that the top of the plastic channel extension perfectly fits at the water storage tank's cover aperture. Repeat the step for the second flap.

\* Use two wrench keys in order to avoid the copper tube mechanical strain.

## SUPPORT BASE ASSEMBLY ON AN INCLINED SURFACE

**ATTENTION!** After the installation check that the collectors surface has a tilt angle to the horizontal position of geographical latitude  $\pm 5^\circ$ .

1. Screw part 1 to part 2, using the M8 screws and nuts included in the packaging. Repeat for the second pair.

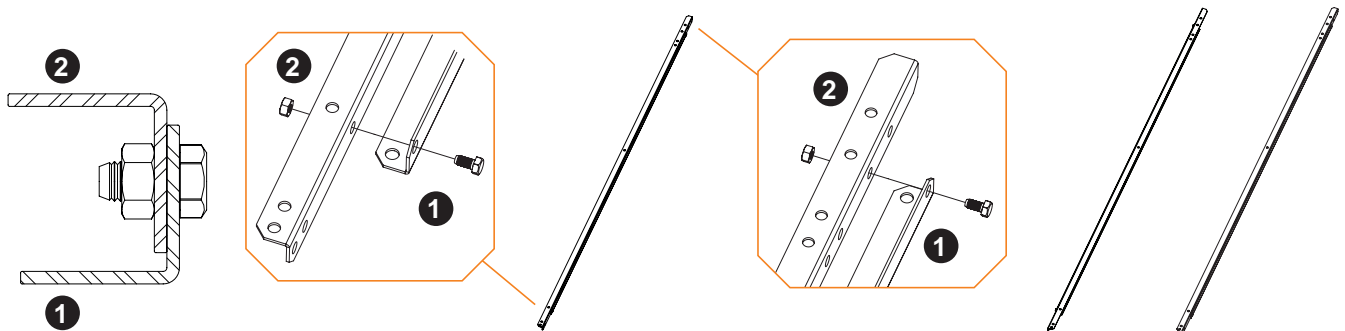

2. Place part 4 between the two  $\Pi$  shape parts constructed in the former step 1 in order for the frame to be formed. Screw straight parts 6 (which will be used for the mounting of the support base to the tiles) to the bottom part. Repeat for the rest of the parts.

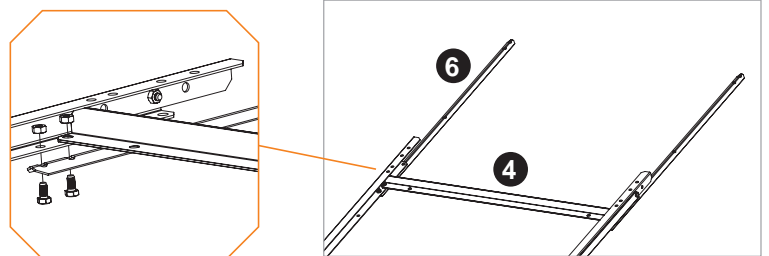

3. Screw the collector supporting part 5 to the bottom part of the frame and tighten the screws.

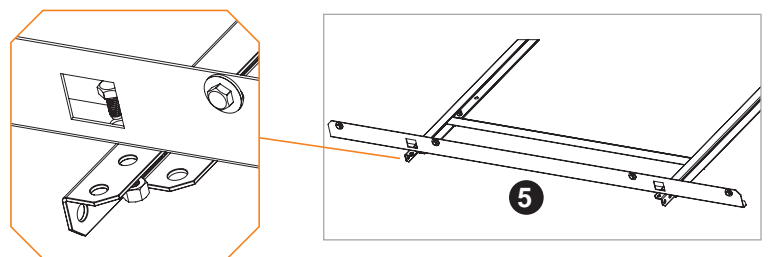

4. Screw the collector supporting part 5 to the top part of the frame without tightening the screws.

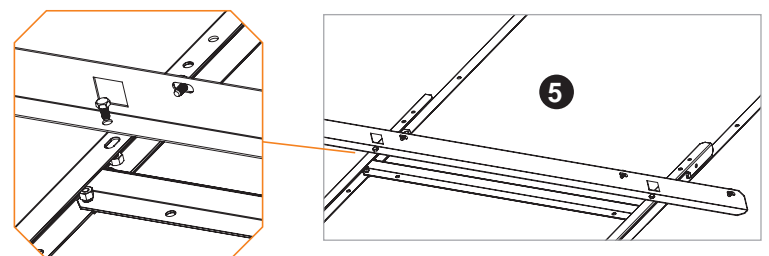

5. Bend the straight parts 6 of step 2 with the hand covering the beams of the tiled roof. Drill and fasten up with bolts. Use level so that the base is horizontally placed.

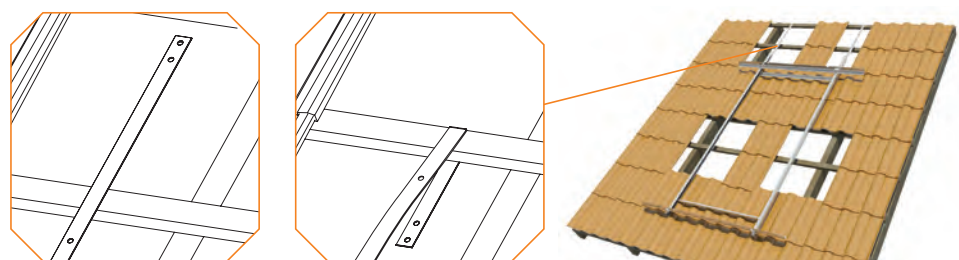

6. In case of two collectors, first place the left one to the bottom part **5** lifting the upper part **5**. Place the screws with the support washers of the collector (4 for each collector) without tightening them. Place the Ø22 mechanically tightened unions at the edges of the collector.

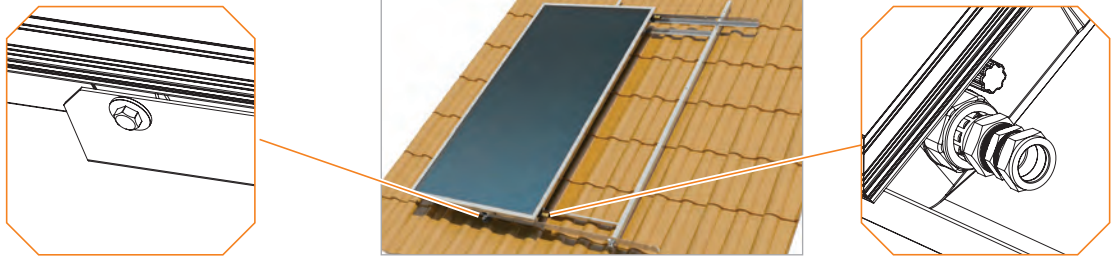

7. Join the second collector and tighten the union\*.

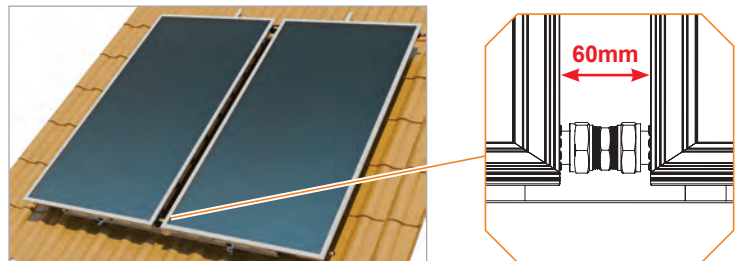

8. Screw on the two supports of the tank. Tighten all screws on the base.

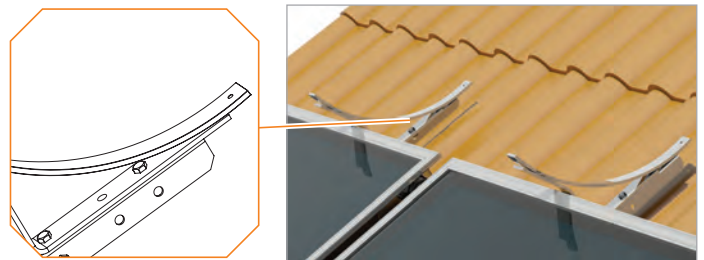

9. Place the decorative covers at the external collector's sides adjusting the channel's aperture at the collector's socket. Screw the channels at the special collector's metal piece using the screws and the corresponding nuts.

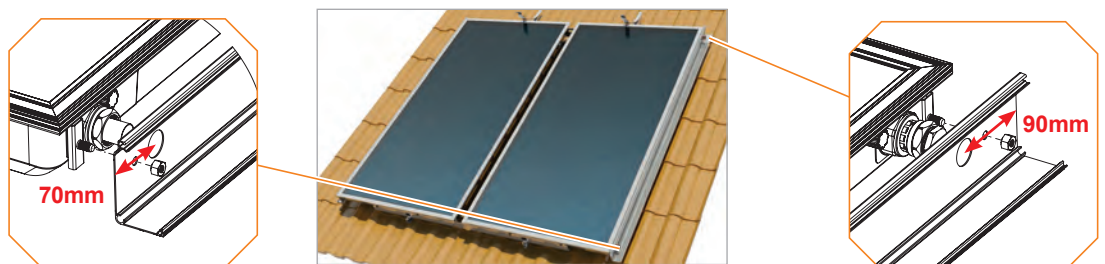

10. Place and tighten the Ø22 mechanically tightened plug on the top right and the bottom left of the collector/collectors\*. Place the water storage tank on the base with its electrical components to the left, when viewing the water storage tank from the front.
11. Centre the water storage tank's position on the collector/s. Rotate the water storage tank (if necessary) in order for the cold and hot domestic water sockets to be vertical to the horizontal level. Screw the water storage tank onto the base using the screws provided in the packaging. Ensure the appliance is not tilted and is properly leveled. It is necessary to use a level
12. Place the small flexible tube on the special connection 3/4"xDN16 INOX at the water storage tank's side where the heating element is located and to the socket marked "collector intake".

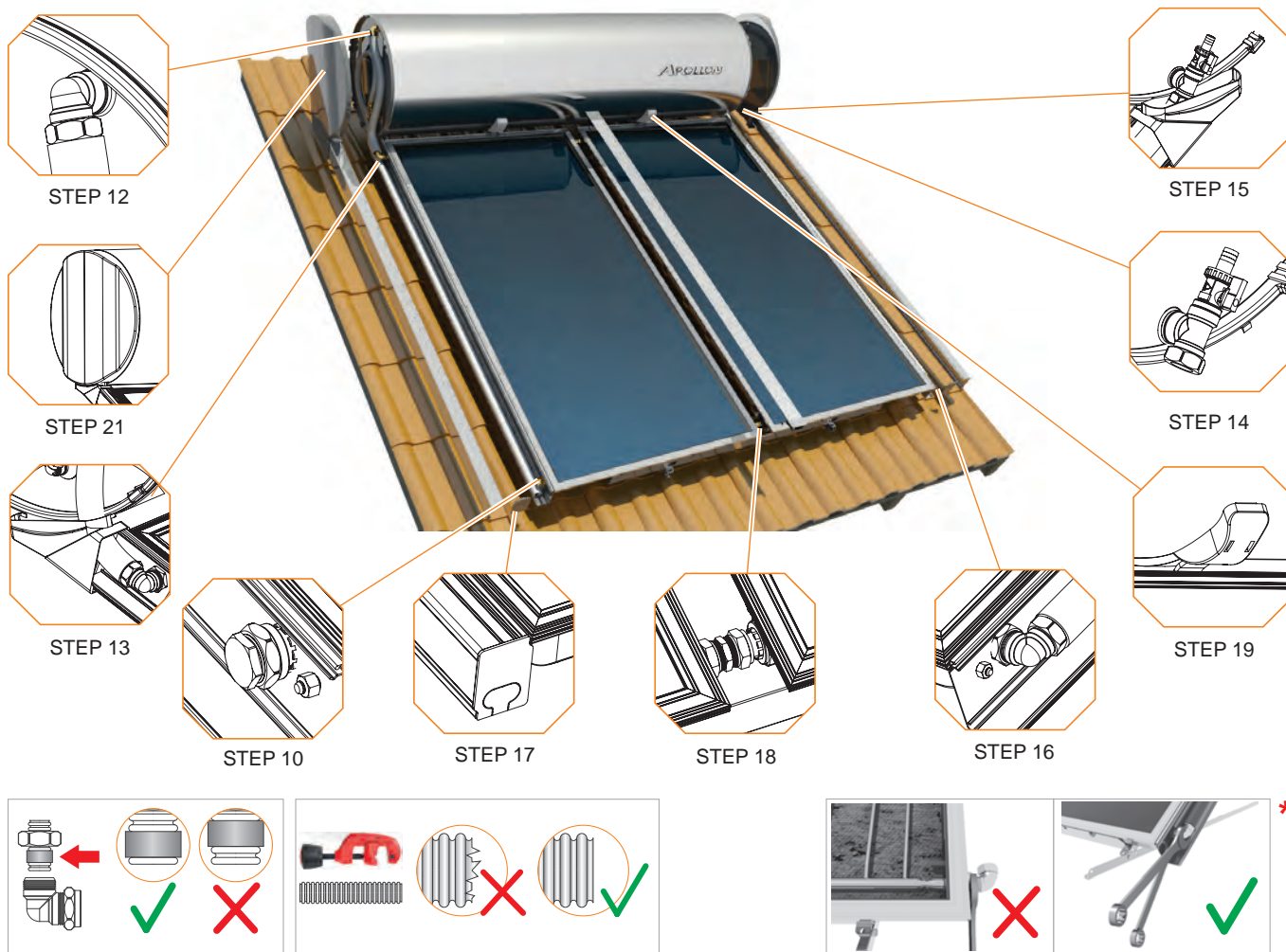

13. Join the other end to the top left socket of the collector using the Ø22x DN16 INOX corner fitting,\* having firstly passed the tube through the plastic channel extension.  
**NOTE:** Through the above extension, pass the cold and hot domestic water sockets during the hydraulic connection.
14. Place the T- piece with the filling valve to the socket on the right side of the water storage tank marked "collector return".
15. Place the big flexible tube with the special connection to the T- piece on the right side of the water storage tank, since we first pass the tube from inside the plastic channel extension.  
 Screw the water storage tank onto the base using the screws provided in the packaging.
16. Place the other end at the bottom right socket of the collector using the Ø22x DN16 INOX corner fitting  
 Tighten all unions in the system as well as all the screws on the base.  
 Make the hydraulic connection, fill the closed circuit and make the electrical connection as described in the relevant sections. Check for possible leaks.
17. Fit all pipe covers and fasten with the plugs on the bottom part.
18. Place the middle cover at the upper socket. After having placed the collectors at a parallel to each other position, fasten them to the bottom side.
19. Fit the water storage tank support base covers.
20. Fit the plastic channel extension at the pipework cover. Check that the water storage tank is completely centred with the plastic channel extensions.
21. Align the water storage tank external flap with the sockets and press to fasten, making sure that the top of the plastic channel extension perfectly fits at the water storage tank's cover aperture. Repeat the step for the second flap.

\*Use two wrench keys in order to avoid the copper tube mechanical strain.

## HYDRAULIC CONNECTION

### CONNECTING THE SYSTEM WITH THE COLD AND HOT WATER MAINS

The “COLD WATER INLET” and “HOT WATER OUTLET” sockets colored blue and red respectively are located on the side of the water storage tank.

**ATTENTION!** The connections to the hot and cold water pipes should be made with union nuts and not by soldering.

1. Onto the “COLD WATER INLET” the Elbow 1/2” Female X 1/2” Male is screwed first, followed by safety valve. The cold water pipe is then connected to the safety valve with an insulated plastic pipe (**Image A1**).

**NOTE:** The safety valve should have a drain pipe connected to its outlet. This pipe should run to ground level where hot water discharge is safe and clear of any paved areas. Do not seal or block the ends of this drain pipe or the valve outlet. Drinking water may be drained from this pipe during high irradiation situations.

2. The “HOT WATER OUTLET” is then connected to the hot water pipe of the consumer network through an insulated plastic pipe (Plastic pipes are recommended to minimize electro-corrosion).
3. Filling the water storage tank WITH WATER: With the ball valve and a hot water tap open, the water storage tank is allowed to be filled with cold water. When water starts to run out of the tap, the water storage tank is full and the hot water tap can be closed.
4. At the solar water heater we place a thermostatic valve, regulated at 38°C to avoid hot water burns.



A1



A2



A3

## CLOSED LOOP FILLING

**ATTENTION!** Before starting to fill the closed loop with anti freeze liquid, the water storage tank has to be completely filled with water.

1. Connect the water mains to the specially designed filling fitting on the right of the water storage tank (**Image A2**) & fill approx. half of the closed loop. Add water to the anti freeze liquid, putting double quantity of water in an empty pot. Disconnect the water mains from the filling fitting & empty the anti freeze liquid solution that we have prepared with the help of a funnel. Connect again the water mains and fill the closed loop completely.

**ATTENTION!** The last filling phase should be realized with controlled flow, given that at the closed loop overflow (safety valve connection point) the fluid may reach high temperatures, which may mean risk of skin burns.

2. When the closed loop is completely filled, securely tighten the safety valve in position (**Image A3**) and disconnect the mains from the special filling fitting.
3. Uncover the collectors and clean the glass removing all the information stickers.
4. Check for leaks and make sure that all pipe joints to the collectors and the water storage tank, as well as the cold & hot water pipes towards the system are properly insulated, in order to avoid thermal loss and protect them against frost.
5. After the completion of the installation, no hot water should be consumed for a couple of hours (depending on the weather conditions and the solar irradiation), in order for the closed loop to be set in operation.

**ANTI FREEZE LIQUID** is an advanced, propylene glycol based special product, designed and formulated in order to ensure effective heat transfer properties at high or low temperatures. It is non-toxic and provides protection up to -37°C (solution 55% v/v with water). It is especially designed to provide excellent anticorrosion properties. In aqueous solutions anti freeze liquid offers protection according to the extent of dilution as per in the table below:

PERCENTAGE %	5	10	15	20	25	30	40	45	50	55
TEMPERATURE °C	-2	-4	-6	-8	-11	-15	-19	-24	-30	-37



### ELECTRICAL CONNECTION

#### DESCRIPTION OF ELECTRICAL COMPONENTS (heating element - thermostat - accessories)

##### ELECTRICAL DIAGRAM - General rules

The electrical installation of the solar water heater should be carried out by a qualified electrician and in accordance with the national regulations in force and the rules and conditions that apply to the building where the installation is taking place.

The heating element must not be switched on when there is no water in the water storage tank. In such case the heating element warranty does not apply.

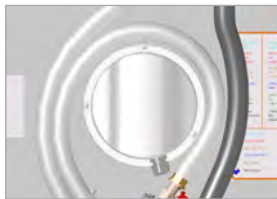

B1

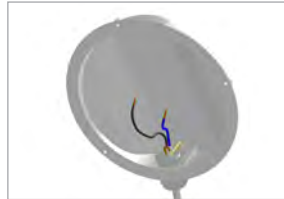

B2

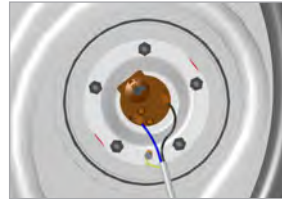

B3

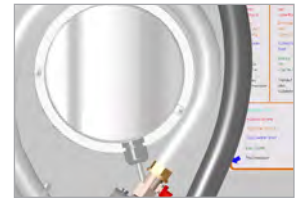

B4

**NOTE:** The heating element's rating depends on local regulations of the country of destination.

1. Remove the screws from the protection flap which covers the electrical components (**Image B1**).
2. A 3x4mm<sup>2</sup> section electrical cable (for a 4kW heating element) is required to connect the heating element to the mains.
3. Pass the end of the cable through the gland and towards the electrical components (**Image B2**).
4. Connect the black wire (phase) to the connector L and the blue wire (neutral) to the connector N on the thermostat. Connect the yellow wire (earthing) to the small M4 screw on the heating element marked with the ground symbol (**Image B3**).
5. The thermostat has been connected to the heating element at the factory. Adjust the thermostat to 60°C.  
**ATTENTION!** The thermostat should be well fitted at the heating element (**Drawing 1**).
6. Close the cover of the electrical components (**Image B4**).
7. Switch off the central mains switch.
8. Connect the other end of the cable to the electrical board using a bipolar disconnection switch with a minimum distance between contacts of at least 3mm. The circuit breaker's rating must be suitable for the heating element in use.

**Caution!** A safety relay against electrical shock is absolutely necessary.

**NOTE:** The daily hot water (40°C) load which can be met by the system without any contribution from solar energy (that is, only through 24h 2kW heating element operation), according to 5.10 of EN 12976-2:2000, is this of maximum 1000lt.

## Drawing 1

### ELECTRICAL COMPONENTS (Heating Element - Thermostat)

#### THERMOSTAT AUTOMATIC AUXILIARY THERMOELECTRIC FUSE

This is tripped when the water storage tank's internal temperature exceeds 95°C and shuts down the thermostat, to protect the appliance from overheating.

#### RESETTING THE THERMOELECTRIC FUSE

Rotate the temperature regulator until the button of the thermoelectric fuse appears and press it. Once the fuse has been reset to its normal operating position (pressed in), the thermostat can operate again.

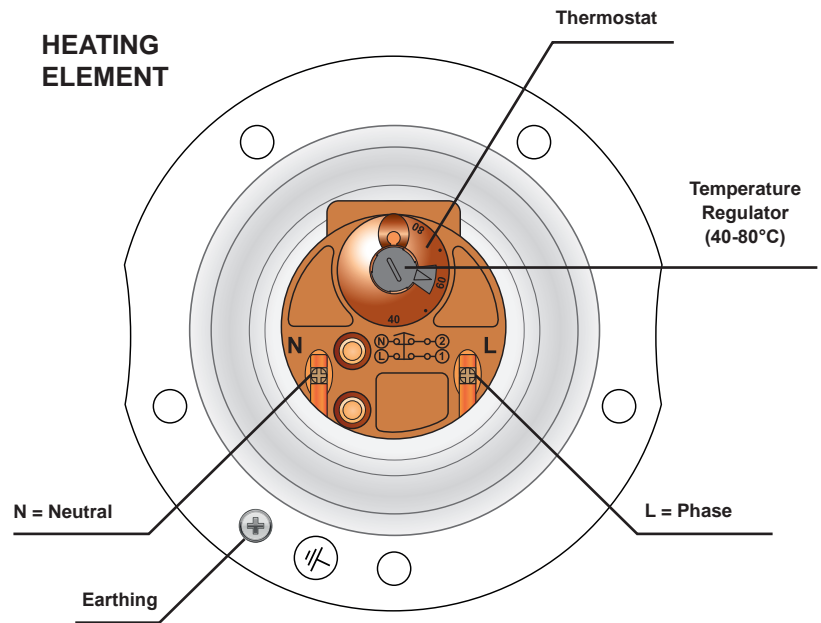

## SYSTEM INSTALLATION ON A TILED ROOF WITH THE WATER STORAGE TANK UNDER THE ROOF (Natural circulation operation)

For the system's optimum operation using natural circulation, the maximum and minimum distances and angles for the pipes must be respected. The maximum distance between the collector outlet and the water storage tank inlet must not exceed 3m. The angle of the pipe joining these 2 points must not be less than 8°.

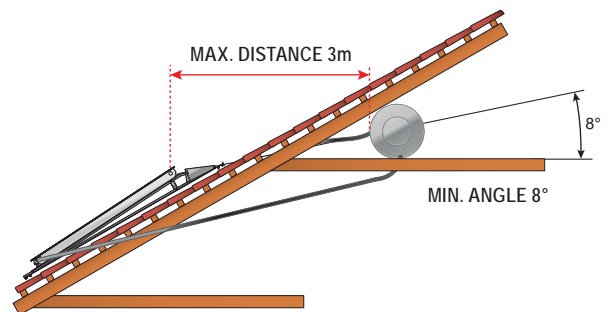

## CONNECTING THE HEAT EXCHANGER

This concerns triple action solar systems equipped with a large exchange surface coil, for the alternative heating of the water using the central heating system. The coil is placed in front of the electric parts.

### HYDRAULIC CONNECTION

The central heating system to which the solar system is to be connected must be equipped with:

- Solar system isolation valves.
- Automatic relief valves at the highest point of the pipes, which must be very well insulated.
- Suitably angled connecting pipes so as not to trap air in the circuit.
- The connections to the coil heat exchanger must be made through unions.

**Specifically:** To connect the coil heat exchangers of the solar system to the central system water storage tank, follow the steps below:

1. Place unions on the inlet E and on the outlet O of the exchanger.
2. Place a ball valve of suitable V diameter.
3. Place automatic relief valves D on both the water supply and return lines of the central heating water storage tank.
4. Insulate all connecting piping with at least 9mm of insulating material.
5. Adjust the automatic filling valve AF, 1/2 bar above the static height H (e.g. for a height of 15m, it should be set to 2 bar).
6. Fill the system with water and check for leaks.

- A. Circulator
- B. Central heating water storage tank
- C. Expansion tank

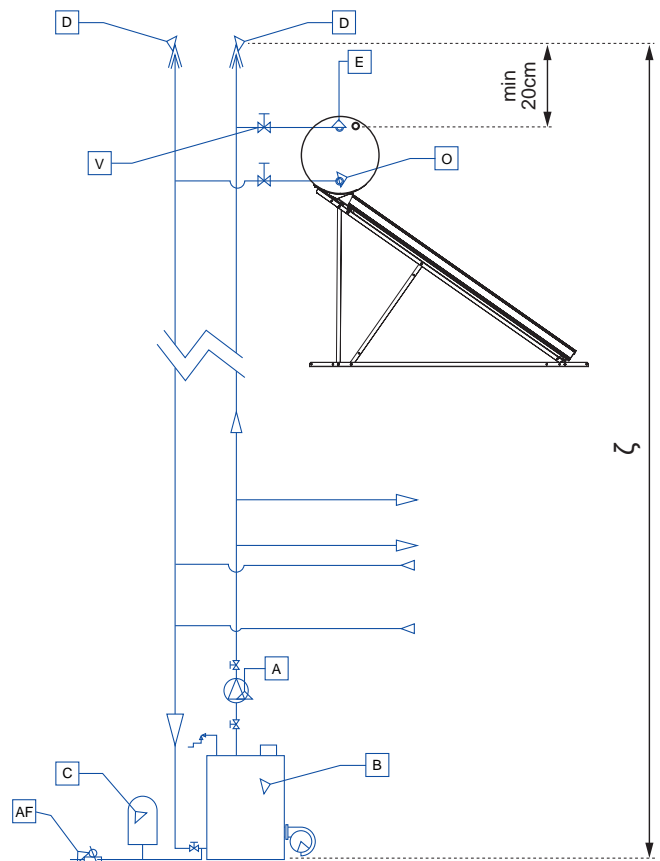

## POSSIBLE PROBLEMS - SOLUTIONS

### THE SOLAR WATER STORAGE TANK DOES NOT SUPPLY A SATISFACTORY AMOUNT OF HOT WATER BY SOLAR POWER

In this case follow these steps:

1. Take the weather conditions into consideration.
2. Avoid large hot water consumption during the night.
3. Check if your needs in hot water have increased and cannot be covered by the system's capacity.
4. Make sure your solar water heater is not shaded by any kind of obstacles.
5. Check that the system is leveled.
6. Check carefully all connections for tightness and tighten or replace any connections that are not tight.
7. Check the building's piping and taps for the possibility of slow leakage.
8. Make sure the hot water supply is not mixing with a cold water supply.
9. Make sure the connecting pipes are not kinked.
10. Check the level of the antifreeze liquid and top up if necessary.
11. Make sure there is no trapped air in the water storage tank or the collectors.

*If after all the above checks you are still not satisfied with your solar system's performance, then please contact your local representative or the company's technical department.*

## THE SOLAR WATER STORAGE TANK DOES NOT SUPPLY HOT WATER WHEN USING THE ELECTRICAL HEATING ELEMENT

The following tasks must be carried out only by a qualified electrician.

1. Shut down the electrical supply and open the electrical components' cover.
2. Check the cable connection between the thermostat and the heating element.
3. Check the temperature at which the thermostat is set, so that it is not lower than that needed for consumption.
4. Check the heating element.
5. Check the central electrical connection.
6. Switch on the electrical current and measure the voltage at the heating element's terminals.
7. Check the thermostat's thermoelectric fuse, which must be pressed in. If it is not, rotate the thermostat's regulator until the button of the thermoelectric fuse appears. Press this. Once it has been reset, the thermostat can operate once again.

## SERVICE - MAINTENANCE

Your solar water heater should be serviced every two years by an authorized representative or a company technician. These periodic checks are necessary for the solar water heater's warranty to apply. The inspection concerns the whole system and more specifically:

1. Flange
2. Safety valve
3. Heating element - thermostat
4. Connection fittings
5. Piping
6. Insulation - seals
7. Transparent cover (solar glass)
8. Supporting system
9. Replacement of anode and checking the closed loop's liquid.

*It is recommended that the water storage tank is cleaned of mineral deposits and sludge every five years.*

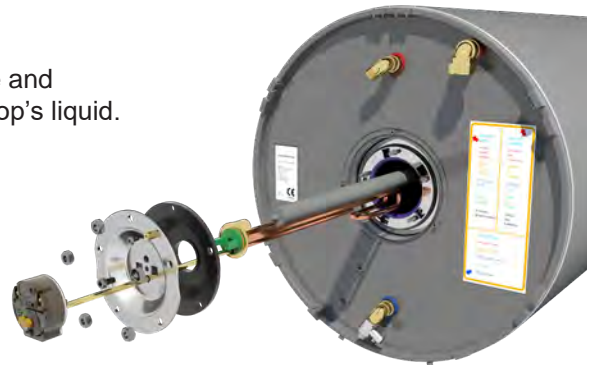

**Especially for the replacement of the anode bar follow these steps:**

1. Shut down the electrical supply.
2. Empty the water from the water storage tank.
3. Remove the electrical component's cover.
4. Disconnect the three electrical wires.
5. Remove the electrical heating element by removing the M8 screws.
6. Remove the old magnesium bar from the heating element's flange.
7. Screw in the new magnesium.
8. Replace the heating element with the rubber seal.
9. Unscrew the external magnesium cap located on the water storage tank's right side.
10. Replace the sacrificial anode with a new one on the cap and screw back into place.
11. Open the water supply and a hot water tap until the water storage tank fills up.
12. Check for water leaks.
13. Reconnect the electrical components at their designated positions.
14. Check that the thermostat is securely clipped to the heating element.
15. Replace the electrical component's cover.
16. Reconnect the electrical supply.

### ATTENTION!

- Any intervention - work on the solar water heater must be carried out only by specialized technicians and where electrical components are concerned, only by qualified and licensed electricians.
- All solar water heater service data must be entered on the respective chart on the warranty document (term of warranty).
- In areas where extreme weather conditions are common (hail storms, storms, tornadoes, etc.) it is recommended that the appliance is insured.

## POST INSTALLATION INSTRUCTIONS

Before using the system make a final check. Open all the valves and check for any kind of leakage. Repeat the inspection after 30 minutes. Check if the system is filled with water and antifreeze fluid according to the company's instructions. In case of any failure condition a specialized technician should be called in.

Following its installation, the solar water storage tank needs about 2 days in order to achieve its maximum efficiency. For this reason it is recommended that there is no hot water consumption during the first two days following installation, even if there is ample sunshine.

A basic periodic maintenance will assure the long life and high efficiency of the solar water heater.

- It is recommended that the appliance is inspected in situ according to the instructions stated in the guarantee twice a year and checked for possible damage (breaking) of the collectors' glass, leaks in the connecting piping to the mains and to the consumption system, inspection of the pipe insulation and cleaning of the glass.
- If the collectors' glass is broken, it should be replaced immediately.
- It is recommended that the glass is washed at an hour of low sunlight to avoid damages due to expansion-contraction, due to temperature changes.
- If the fittings are worn (screws, pugs, piping, etc), these should be replaced at the owner's cost.
- The level of antifreeze in the closed circuit must be checked annually (as it could need topping up), to ensure the efficient operation.
- In cases where there is to be no use of hot water for long periods of time (e.g. during the summer holidays), it is recommended that the collector surface is covered with an opaque cover in order to avoid the building up of high temperatures, which could trip the thermoelectric fuse of the thermostat and cut the electrical circuit. (**See the paragraph "RESETTING THE THERMOELECTRIC FUSE"**).
- During the build-up of high pressure in the thermal tank, it is possible that the safety valve will open and water will run out. This is a normal function that protects the water storage tank from high pressures. If the mains pressure exceeds 4 atm., it is necessary to add a pressure reducer - expansion tank.
- Do not switch on the electrical heating element in the following cases:
  - A) When the mains water supply has been cut
  - B) When the connecting pipes have frozen and there is no water flow from the water storage tank to the taps.

**Caution!** Place taps with thermostatic regulation up to 38°C for hot water use to prevent burns which may be caused by the high temperature water in the solar water heater.

**We remain at your disposal for any further information you may need.**

**We can assure you that you have made the best choice.**

**Thank you for choosing our products.**

## CHECK LIST

### INSTRUCTIONS FOR THE INSTALLER

After the installation is complete, the installer, with the help of the check list below has to check all of the points which are noted and mark in the relevant column with a √.

LIST	CHECK
<b>COLLECTORS AND EXTERNAL PIPING</b>	
Is the installation and the fixing of the support base according to the instructions and local regulations?	
Is there an ideal location and facing of the collectors?	
Is there humidity inside the collectors?	
Are the hydraulic connections of the collectors correct?	
Has there been good UV protection on the thermal insulation?	
Is the piping properly insulated?	
Has the installment on the roof been done according to the local regulations?	
<b>HYDRAULIC CONNECTIONS</b>	
Are there any leaks in the closed circuit, the connections, or in the tube heat exchanger ?	
Are the safety valves installed properly?	
Does a mixing valve of hot / cold water exist?	
<b>ELECTRICAL CONNECTION</b>	
Is the electric resistance connected properly? (if it exists)	
Has the electric connection been done according to the local regulations? (insulation, grounding, etc...)	
<b>GENERAL</b>	
Was the guarantee properly filled in and given to the client?	
Were the instructions of use given to the client?	
Was the proper selection of the model made according to the needs of the client?	
Was the client informed of other options for the production of hot water?	

#### Installer Data

Full name.....

Address.....

Telephone.....

#### Distributor Data

Full name.....

Address.....

Telephone.....



## *Solar water heaters*

# **APOLLON<sup>®</sup>**

*Installation, maintenance &  
use instructions*

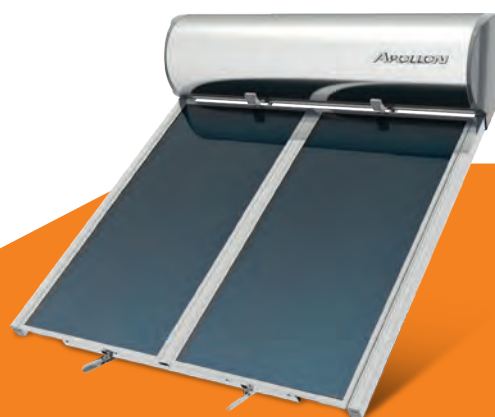

**NOBEL INTERNATIONAL EAD**  
SOLAR WATER HEATING SYSTEMS INDUSTRY

48 Vitosha Blvd., Elin Pelin 2100 - Sofia Region, Bulgaria  
Tel.: +359 2 4210232 email: info@nobel.bg

**[www.nobel.bg](http://www.nobel.bg)**