



*Efficiency and reliability, every day!*

SOLAR WATER HEATERS

*HYPERION*

*The reliable  
choice!*



## HYPERION

### *The reliable choice*

The APOLLON collector meets the AELIOS water tank and the HYPERION solar water heater is born, offering a reliable choice and an effective energy solution. Made of excellent materials, it combines high output and autonomy, and can be simply and quickly installed to supply domestic hot water almost the whole year round.

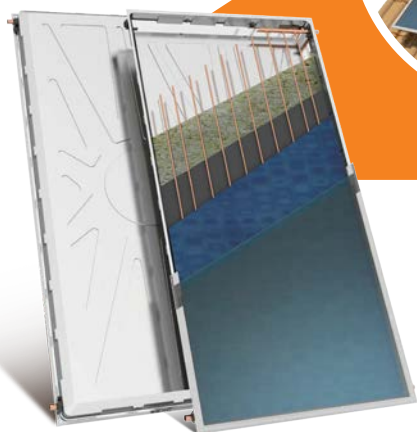

*With the extraordinary Apollon collector, with complete area selective absorber and one-piece aluminum tray*

## TECHNICAL SPECIFICATIONS

### WATER TANK

- External housing naval aluminium alloy.
- Water tank of cold rolled steel with a double internal layer of enamel (GLASS) \*
- Ecological high-density thermal insulation of expanded polyurethane
- Anticorrosion protection
- Antifreeze protection
- Real nominal capacity
- Color: grey / other
- ABS UV PROOF external decorative caps

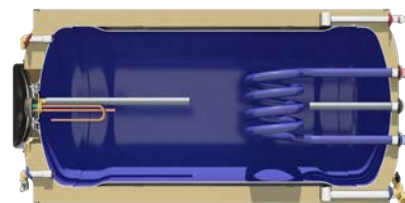

### COLLECTOR APOLLON

- One-piece external seamless tray made of special naval aluminum alloy
- Complete area selective absorber, LASER welding technology
- Tempered solar glass, low-iron, extra clear, of high transmittance and stable expansion coefficient
- High density, eco-friendly thermal insulation, achieved with prepressed rockwool
- Colour: aluminum/other



## SUPPORT BASE AND ACCESSORIES

Galvanized demountable support base, specially designed for simple and quick mounting, electrostatically painted, with stainless steel screws. (One type for flat and inclined surfaces).



AVAILABLE MODELS (ONLY IN GLASS DOUBLE OR TRIPLE ACTION)		
TYPE		
160lt/2.0m <sup>2</sup>	200lt/2.6m <sup>2</sup>	320lt/4.0m <sup>2</sup>

### DIMENSIONS (in cm) FLAT SURFACE

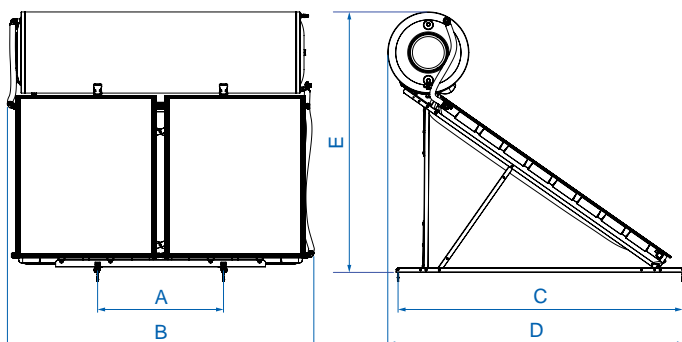

TYPE	A	B	C	D	E
160lt/2.0m <sup>2</sup>	90	112	203	212	186
200lt/2.6m <sup>2</sup>	90	138	203	212	186
320lt/4.0m <sup>2</sup>	90	219	203	212	186

### DIMENSIONS (in cm) INCLINED SURFACE

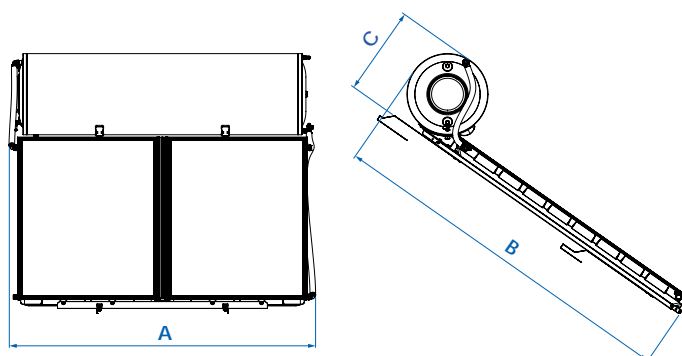

TYPE	A	B	C
160lt/2.0m <sup>2</sup>	112	255	63
200lt/2.6m <sup>2</sup>	138	255	63
320lt/4.0m <sup>2</sup>	219	255	63



*Efficiency and reliability, every day!*

## SOLAR WATER HEATERS

### *HYPERION*

**NOBEL INTERNATIONAL EAD**  
SOLAR WATER HEATING SYSTEMS INDUSTRY

48 Vitosha Blvd., Elin Pelin 2100 - Sofia Region, Bulgaria  
Tel.: +359 2 4210232 email: info@nobel.bg

[www.nobel.bg](http://www.nobel.bg)

